

Project:

Square Ring Pendant Spec Sheet

SKU: 4762.25 Learn more at:
<https://sonnemanlight.com/square-ring-pendant>

Description: Urban strength combines with delicate elegance: A square frame captures a round ring, glorifying a structural geometry and reconciling cylinders composed in a variety of rectilinear patterns. The industrial edge of the metal structure is in intentional juxtaposition with the pristine quality of the clear glass cylinders.

Type #:

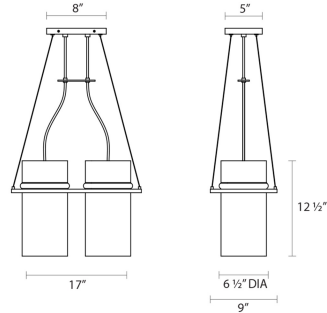

Dimensions

Height:	12.5"
Width:	17"
Length:	9"
Shape:	Rectangle
Size:	2-Light
Canopy/Backplate/Base Width:	8
Canopy/Backplate/Base Depth:	5
Canopy/Backplate/Base Height:	0.5

Electrical Specs

Bulb 1 Type:	Medium Base
Bulb Quantity:	2
Input Voltage:	120VAC
Wattage:	60
Color Temperature:	N/A
Dimming Type:	N/A
Bulb Max Wattage:	60

Installation

Installation:	Licensed electrician required
Sloped Ceiling Compatible?:	Not Compatible

Shipping

Carton 1 L x W x H:	35" X 16" X 9"
Carton 1 Gross Weight:	12 LBS

Shade

Shade 1 Material:	Glass
-------------------	-------

Available Finishes

Available Finishes: Satin Black (.25)

General Listings

Certification:	C-UL-US
Color/Finish:	Satin Black (.25)
Dark Sky Friendly:	N