

# ASSEMBLY INSTRUCTIONS

## ITEM DESCRIPTION:

ITEM NO.: DA49016	NAME: Bend Sconce
MATERIAL TYPE: Glass	FINISH: Blackened Steel
SOCKET TYPE: E12	SOCKET QTY: 2
BULB WATTAGE: 60W/16W CFL/13W LED	
VOLTAGE: 110-120 V	ITEM NET WEIGHT: 5.2 LBS

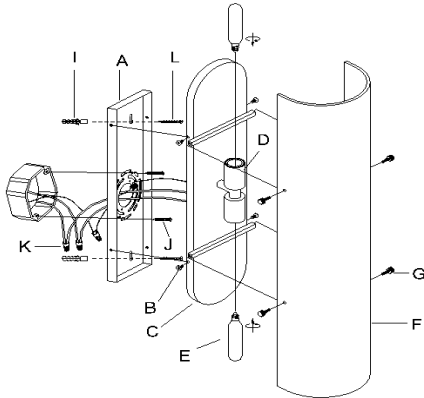

## PARTS INCLUDED:

(A) Mounting Plate	Qty: 1
(B) Canopy Screw	Qty: 4
(C) Lamp Body	Qty: 1
(D) Socket	Qty: 2
(E) Bulb - Not Include	Qty: 2
(F) Glass	Qty: 1
(G) Thumb-Screw	Qty: 4
(I) Anchor	Qty: 3
(L) Strengthen Screw	Qty: 3

## HARDWARE INCLUDED:

(J) Mounting Screws
(K) Plastic Wire Connector

## TOOLS NEEDED (Not Included):

Screwdriver

These instructions are provided for safety. It is very important that they are read carefully and completely before beginning installation.

We strongly suggest that all hard-wired fixtures must be installed by a professional electrician.



## TO ASSEMBLE:

1. Shut off the main electrical supply from the main fuse box/circuit breaker.
2. Gently pull the electrical cord from the junction box, then pull the electrical cord from the back plate through the exit hole of the mounting plate (A).
3. Remove the mounting plate (A) from the lamp body (C) by loosening the screws (B).
4. Position fixture in desired location on the wall. The mounting plate (A) features two holes for screw mounting. Mark these spots on the wall with a pencil and drill two holes. Insert the plastic wall anchors (I) into the drilled holes. Place the mounting plate (A) so that the holes are aligned with the holes on the wall. Fasten it loosely with strengthen screws (L) to check the alignment.
5. Carefully inspect the fixture wires. The neutral fixture wire has very fine ridges molded into its plastic covering. The hot fixture wire has a smooth covering. The bare wire is the grounded wire.
6. Attach the ground wire from the fixture to the ground junction box wire from the outlet (usually green or bare wire). Fasten each together with a plastic wire connector (K) and wrap the connection with electrical tape. If your outlet box does not have a ground wire, insert the green ground screw into the mounting plate (A) facing down, and wrap the fixture's bare ground wire around the ground screw. **IT IS IMPERATIVE THAT THE OUTLET BOX IN YOUR HOME BE PROPERLY GROUNDED.**
7. Connect the neutral fixture wire to the neutral junction box wire (usually white). Fasten each together with a wire connector (K) and wrap the connection with electrical tape. Be sure no wire strands are exposed.
8. Connect the hot fixture wire to the hot junction box wire (usually black). Fasten each together with a plastic wire connector (K) and wrap the connection with electrical tape. Be sure no wire strands are exposed. **DO NOT REVERSE THE HOT AND NEUTRAL CONNECTIONS OR SAFETY WILL BE COMPROMISED.**
9. Gently tuck the wire connections neatly into the junction box.
10. Attach the mounting plate (A) to the outlet box by using the mounting screws (J) and tighten with a screwdriver.
11. Attach the lamp body (C) to the mounting plate (A) by using the enclosed canopy screws (B) and tighten with a screwdriver.
12. Affix the glass (F) onto the lamp body (C) and secure with the four thumb-screws (G).
13. Restore power to junction box and test fixture. **DO NOT EXCEED SPECIFIED MAX WATTAGE.**

## CARE INSTRUCTIONS:

Wipe with a soft, dry cloth. To protect finish, avoid the use of chemicals and household cleaners.

For customer service questions call 1-800-338-2150

ARTERIO RS