

ASSEMBLY INSTRUCTIONS

ITEM DESCRIPTION:

ITEM NO.: 49525	NAME: Redmond Sconce
MATERIAL TYPE: Alabaster, Iron	FINISH: Antique Brass, White
SOCKET TYPE: E12	SOCKET QTY: 2
BULB WATTAGE: 8W	
VOLTAGE: 110-120V	ITEM NET WEIGHT: 10.5LBS

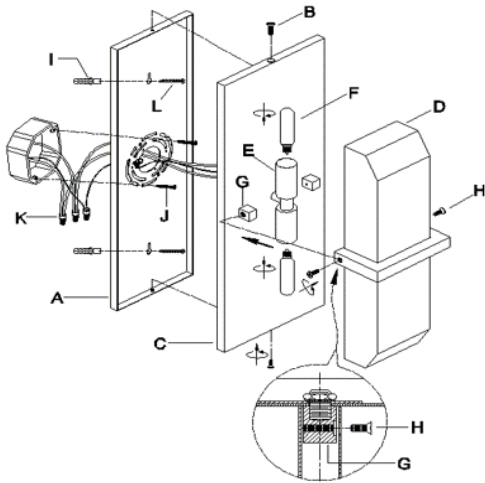
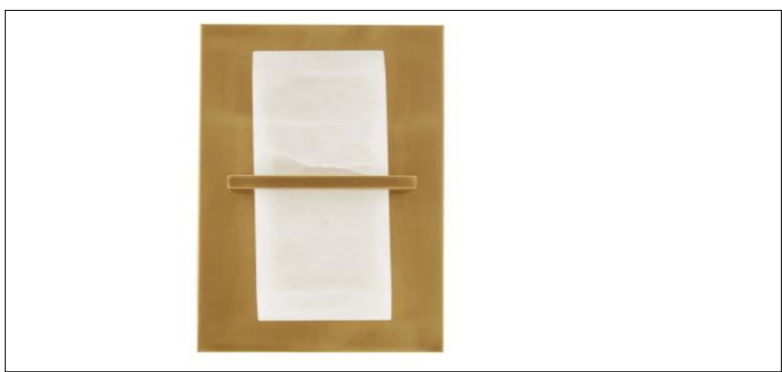

TO ASSEMBLE:

1. Remove all packing contents and parts from the carton(s) carefully.
2. Please be sure you have all parts indicated before you begin assembly.
3. Shut off the main electrical supply from the main fuse box/circuit breaker.
4. Remove the mounting plate (A) from the lamp body (C) by turning back plate screws (B) in a counterclockwise direction.
5. Pull the electrical cord of "J Box" through the exit hole of the mounting plate (A).
6. Carefully inspect the fixture wires. The neutral fixture wire has very fine ridges molded into its plastic covering. The hot fixture wire has a smooth covering. The bare wire is the grounded wire.
7. Attach the ground wire from the fixture to the ground junction box wire from the outlet (usually green or bare wire). Fasten each together with a plastic wire connector (K) and wrap the connection with electrical tape. If your outlet box does not have a ground wire, insert the green ground screw into the mounting plate (A) facing down, and wrap the fixture's bare ground wire around the ground screw. IT IS IMPERATIVE THAT THE OUTLET BOX IN YOUR HOME BE PROPERLY GROUNDED.
8. Connect the neutral fixture wire to the neutral junction box wire (usually white). Fasten each together with a wire connector (K) and wrap the connection with electrical tape. Be sure no strands are exposed.
9. Connect the hot fixture wire to the hot junction box wire (usually white). Fasten each together with a plastic wire connector (K) and wrap the connection with electrical tape. Be sure no strands are exposed. DO NOT REVERSE THE HOT AND NEUTRAL CONNECTIONS OR SAFETY WILL BE COMPROMISED.
10. Gently tuck the wire connections neatly into the junction box.
11. Drill two holes in wall in line with 2 holes of mounting plate (A), attach the mounting plate (A) to the outlet box using the mounting screws (J) and tighten with a screwdriver. Then screw the strengthened screws (L) into the anchors to secure the mounting plate (A). If attached to a cement wall, use anchor (I) first then screw strengthened screws (L) into the anchor. If attached to a wood wall, thread strengthened screw (L) directly into wall.
12. Attach the lamp body (C) to the mounting plate (A) by using the enclosed back plate screws (B) and tighten screws (B) with screwdriver.
13. Insert 2 type T max 8W LED bulbs (F) only (not included) into the sockets (E). DO NOT EXCEED SPECIFIED WATTAGE.
14. Attach alabaster shade (D) to the lamp body (C), and then tighten the alabaster shade (D) by 2 set screws (H) to secure the alabaster shade (D).
15. Restore power to the junction box and test fixture.

PARTS INCLUDED:

Mounting Plate (A)	Qty: 1
Back Plate Screw (B)	Qty: 2
Lamp Body (C)	Qty: 1
Alabaster Shade (D)	Qty: 1
Sockets (E)	Qty: 2
Bulb (Not Included) (F)	Qty: 2
Set Anchors (H)	Qty: 2
Anchor (I)	Qty: 3
Strengthened Screw (L)	Qty: 3

HARDWARE INCLUDED:

Mounting Screws (J)	Strengthened Screw (L)
Plastic Wire Connector (K)	
Anchor (I)	

TO INSTALL YOU WILL NEED:

- 2 people recommended
- Phillips Screwdriver

These instructions are provided for safety. It is very important that they are read carefully and completely before beginning installation of this chandelier.

We strongly suggest that all hard-wired fixtures must be installed by a professional electrician.

CARE INSTRUCTIONS:

Wipe with a soft, dry cloth. To protect finish, avoid the use of chemicals and household cleaners.

For customer service questions call 1-800-338-2150

ARTERIO RS