

ASSEMBLY INSTRUCTIONS

ITEM DESCRIPTION:

ITEM NO.: DMC20 NAME: Bennet Chandelier

MATERIAL TYPE: Steel FINISH: Antique Brass

SOCKET TYPE: Integrated LED SOCKET QTY: 1

BULB WATTAGE: 45W LED

VOLTAGE: 110-120 V ITEM NET WEIGHT: 42LBS

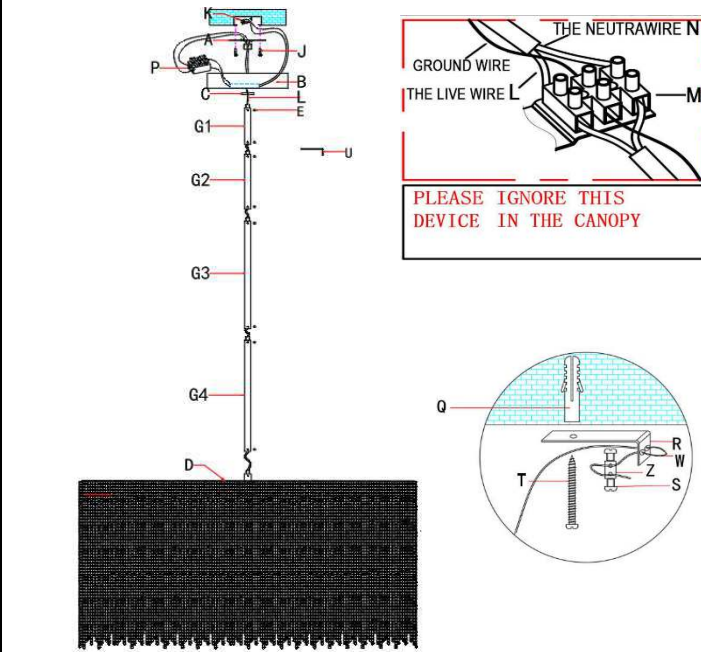

PARTS INCLUDED:

Mounting Plate(A)	1PC	Rod(G1,2,3,4)	4PCS
Canopy(B)	1PC	Mounting Screw(J)	2PCS
Collar (C)	1PC	Plastic Wire Connector(K)	3PCS
Lamp Body(D)	1PC	The 2-Wire Terminal(P)	1PC
Hex Screw (E)	12PCS	Power Wire(L)	1PC
Screw(S)	2PCS	Coupling (Z)	1PC
Anchor (Q)	1PC	Aircraft Wire (W)	1PC
Bracket(R)	1PC	Fast Connector (P)	1PC

HARDWARE INCLUDED:

Mounting Screws	2	Hexangular Screw	8
Plastic Wire Connector	3	Allen Wrench	1
Green Ground Screw	1		

TO INSTALL YOU WILL NEED:

- 2 people recommended
- Phillips Screwdriver

These instructions are provided for safety. It is very important that they are read carefully and completely before beginning installation.

We strongly suggest that all hard-wired fixtures must be installed by a professional electrician.

TO ASSEMBLE:

1. Shut off the main electrical supply from the main fuse box/ circuit breaker.
2. Carefully unpack all fixture parts and hardware and lay them on a soft surface for assembly.
3. Gently pull wiring down from ceiling junction box and allow to hang.
4. Pass the power wire(L) through the rod (G4), (G3), (G2) &(G1), screw the rod(G4) to lamp body(D) till tight, repeat the same operation on the rod(G3), (G2) and rod(G1). When you connect the rods, loosen the small hex screws(E) in the side hole first then tighten with Allen wrench(U) after all rods are connected. Be sure all the hexangular screws are tight enough.
5. Remove mounting plate from the canopy by unscrewing the collar.
6. Put the collar(C) and canopy(B) into the rod (G1) in turn, then pass the power wire(L) through the mounting plate(A). Screw the rod(G1) to the nipple of mounting plate(A) till tight.
7. Drill one hole on the ceiling and insert anchor(Q) into drilled hole, then fix bracket(R) to the ceiling with strengthened screw (T) by screwing into anchor(Q). Remove the coupling(Z) from the aircraft wire(W) by loosening (2) screws(S). Pass the aircraft wire(W) through (2) holes on the bracket(R). Then pass the aircraft wire(W) through (2) holes on the coupling(Z) and fix with (2) screws(s) as Fig1. or you can find more details on next page. Be sure to tighten two screws attached on the coupling(Z).
8. PLEASE PAY SPECIAL ATTENTION THAT YOU DO NOT NEED TO CONNECT THE WIRE CONNECT DEVICE(M). IT IS USED FOR THE WIRE CONNECTION FOR EURO-MARKET.
9. Carefully inspect the chandelier's fixture wires. Neutral fixture wire: White Hot fixture wire: Black Ground wire: Bare wire
10. Wrap ground wire of lamp assembly and ground wire of junction box together and fasten together with a wire nut and wrap the connection with electrical tape.
11. Attach the neutral fixture wire from the chandelier to the neutral junction box wire (usually white). Fasten each together with a wire nut and wrap the connection with electrical tape.
12. Attach the hot fixture wire from the chandelier to the hot junction box wire (usually black). Fasten each together with a wire nut and wrap the connection with electrical tape. DO NOT REVERSE THE HOT AND NEUTRAL CONNECTIONS OR SAFETY WILL BE COMPROMISED.
13. Connect the power wires (L) of the lamp together using the fast connector (P). Connect the black wire to the positive electrode and the white wire to the negative electrode of the fast connector (P).
14. Gently tuck the wire connections(K) neatly into the ceiling junction box.
15. Place the mounting plate(A) over the center of the ceiling junction box.
16. Align holes in mounting plate(A) with holes in junction box and attach with two mounting bolts(J). Secure bolts with a Phillips head screwdriver.
17. Push canopy up over the mounting plate until it is flush with the ceiling.
18. Push collar through hole in canopy and thread onto nipple on the mounting plate.

CARE INSTRUCTIONS:

Wipe with a soft, dry cloth. To protect finish, avoid the use of chemicals and household cleaners.

For customer service questions call 1-800-338-2150

ARTERIO RS

AIRCRAFT WIRE ASSEMBLY INSTRUCTIONS

1. ATTACH THE AIRCRAFT WIRE(R) TO A SOLID STRUCTURE IN ACCORDANCE TO LOCAL BUILDING CODE.
2. POSITION THE BRACKET(O) IN DESIRED LOCATION ON CEILING AND MARK ONE SPOT WITH PENCIL TO DRILL HOLE.
DRILL 1 HOLE ON THE SPOT AND INSERT ANCHOR(Q) INTO DRILLED HOLE.
3. FIX BRACKET(T) WITH STRENGTHENED SCREW (Q) BY SCREWING INTO ANCHOR(R).
- IF ATTACH TO CEMENT CEILING, USE ANCHOR(Q) FIRST THEN SCREW STRENGTHENED SCREW (T) INTO THE ANCHOR(Q).
IF ATTACH TO WOOD CEILING, THREAD STRENGTHENED SCREW (T) DIRECTLY INTO CEILING.
4. REMOVE THE COUPLING(Z) FROM THE AIRCRAFT WIRE(W) BY LOOSENING THE (2) SCREWS(S) BEFORE INSTALLATION.
5. PASS THE AIRCRAFT WIRE(W) THROUGH THE (2) HOLES ON THE BRACKET(R) AS THE DRAWING.
6. THEN PASS THE AIRCRAFT WIRE(W) THROUGH THE (2) HOLES ON THE COUPLING(Z) AND FIX WITH (2) SCREWS(S) AS THE DRAWING AND THEN TIGHTEN (2) SCREWS(S) WITH A SCREWDRIVER.

