

ARTERIOS

EMPIRE LAMP

LAURA KIRAR

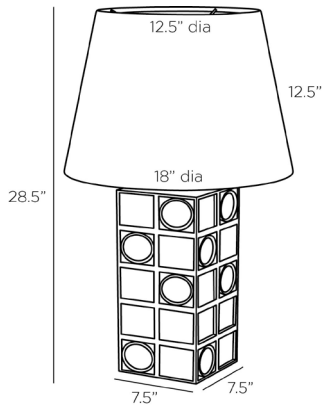

GKPTC02-SH019
H: 28.5 IN, Dia: 18.00 IN
Ivory, Riverstone
Contract Suitable As Is

As part of The Empire series of objects: this ivory table lamp created of riverstone composite and antique brass uses the ideas of origami and geometry as a kind of mystical decorative language conjuring up both treasures of the past and the future. These are the jewelry of the collection, a precise and polished counterbalance to the more hand-hewn objects. Finish will vary.

APPEARANCE

Material	Cotton, Iron, Microfiber, Riverstone
Finish	Antique Brass, White
Finish Will Vary	true
Top Coat/Sealant	true
Finial Description	Antique Brass Cylinder
Finial Dimension	0.5" x 1.5"

DIMENSIONS

Shade	Top: 12.50 IN, Dia: 18.00 IN, Side: 12.5 IN
Body	H: 15.5 IN, W: 7.5 IN, D: 7.5 IN
Neck	H: 5.75 IN, Dia: 0.50 IN
Foot Print	W: 7.5 IN, D: 7.5 IN

WIRING

Rating	Indoor Only
Suggested Bulb Type	A19
Tilt Test	10 Degrees - AU
Cord	10 FT, Back of Lamp Base, Taupe Fabric
Socket	2, Type A - E26, White
Switch	On Line, On/Off Rocker
Maximum Watt	60
Voltage	110-120 V

COMPLIANCY

RoHS	true
------	------

SHIPPING

Product Weight	18.3 LBS
Gross Weight 1	25 LBS
Shipping Box 1	H: 27.5 IN, L: 11.3 IN, W: 11.3 IN
Shipping Box 2	H: 34 IN, L: 19.3 IN, W: 19.3 IN

ADDITIONAL INFO

Shade Shape	Round
Shade Trim	Rolled Edges
Shade Type	Hardback

REPLACEMENT PARTS

Replacement Part 1	GKPTC02FIN
Replacement Part 1 Dim	0.5" x 1.5"

CONTRACT

Contract Suitable	true
-------------------	------