

ASSEMBLY INSTRUCTIONS

ITEM DESCRIPTION:

ITEM NO.: 89422	NAME: Royalton Large Chandelier
MATERIAL TYPE: Glass	FINISH: Smoke
SOCKET TYPE: E26	SOCKET QTY: 12
BULB WATTAGE: 100W/26W CFL/20W LED	
VOLTAGE: 110-120 V	ITEM NET WEIGHT: 48.5LBS

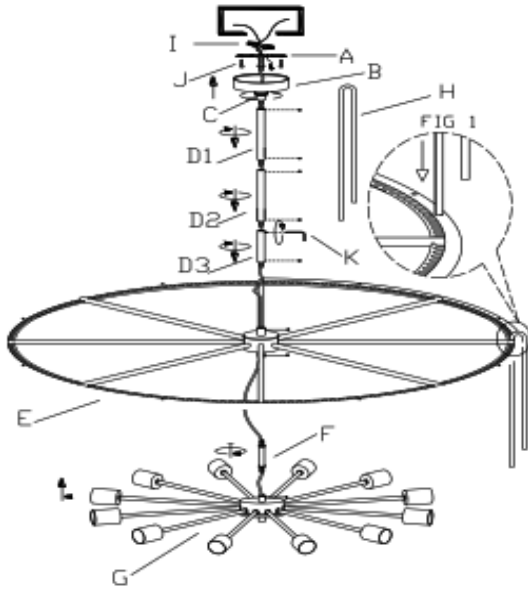

PARTS INCLUDED:

A) MOUNTING PLATE	1 PC	G) SOCKET ASSEMBLY	1 PC
B) CANOPY	1 PC	H) GLASS TUBES	242 PC
C) COLLAR LOOP	1 PC		
D) RODS	3 PC		
E) BIG RING	1 PC		
F) PIPE	1 PC		

HARDWARE INCLUDED:

I) Plastic Wire Connector	2 Pcs	K) Allen Wrench	1 Pc
J) Mounting Screws	2 Pc		

TO INSTALL YOU WILL NEED:

- 2 people recommended
- Phillips Screwdriver

These instructions are provided for safety. It is very important that they are read carefully and completely before beginning installation.

We strongly suggest that all hard-wired fixtures must be installed by a professional electrician.

TO ASSEMBLE:

1. REMOVE ALL PACKING CONTENTS AND PARTS FROM THE CARTON(S) CAREFULLY
2. PLEASE BE SURE YOU HAVE ALL PARTS INDICATED BEFORE YOU BEGIN ASSEMBLY
3. SHUT OFF THE MAIN ELECTRICAL SUPPLY FROM THE MAIN FUSE BOX/CIRCUIT BREAKER
4. THREAD THE PIPE(F) ONTO THE SOCKET ASSEMBLY(G), THEN CONNECT THE PIPE(F) TO THE CENTER CONNECTION WIRE BOX OF THE BIG RING(E), THEN SECURE THE HEXANGULAR SCREWS WITH ALLEN WRENCH(K) TILL
5. SCREW THE ROD(D3) ONTO THE BIG RING(E) AND TIGHTEN THE HEXANGULAR SET SCREW IN THE SIDE DESIRE HOLE BY ALLEN WRENCH(K). REPEAT THE SAME OPERATION ON THE ROD (D1) AND (D2).
6. REMOVE THE MOUNTING PLATE(A) FROM THE CANOPY(B) BY TURNING COLLAR LOOP (C) IN A COUNTERCLOCKWISE DIRECTION.
7. CAREFULLY INSPECT THE FIXTURE WIRES. THE NEUTRAL FIXTURE WIRE HAS VERY FINE RIDGES MOLDED INTO ITS PLASTIC COVERING. THE HOT FIXTURE WIRE HAS A SMOOTH COVERING. THE BARE SILVER WIRE IS THE GROUNDED WIRE.
8. ATTACH THE GROUND WIRE FROM THE FIXTURE TO THE GROUND JUNCTION BOX WIRE FROM THE OUTLET (USUALLY GREEN OR BARE WIRE). FASTEN EACH TOGETHER WITH A PLASTIC WIRE CONNECTOR (I) AND WRAP THE CONNECTION WITH ELECTRICAL TAPE. IF YOUR OUTLET BOX DOES NOT HAVE A GROUND WIRE, INSERT THE GREEN GROUND SCREW INTO THE MOUNTING PLATE (A) FACING DOWN, AND WRAP THE FIXTURE'S BARE GROUND WIRE AROUND THE GROUND SCREW. IT IS IMPERATIVE THAT THE OUTLET BOX IN YOUR HOME BE PROPERLY GROUNDED.
9. CONNECT THE NEUTRAL FIXTURE WIRE TO THE NEUTRAL JUNCTION BOX WIRE (USUALLY WHITE). FASTEN EACH TOGETHER WITH A WIRE CONNECTOR (I) AND WRAP THE CONNECTION WITH ELECTRICAL TAPE. BE SURE NO STRANDS ARE EXPOSED.
10. CONNECT THE HOT FIXTURE WIRE TO THE HOT JUNCTION BOX WIRE (USUALLY BLACK). FASTEN EACH TOGETHER WITH A PLASTIC WIRE CONNECTOR (I) AND WRAP THE CONNECTION WITH ELECTRICAL TAPE. BE SURE NO WIRE STRANDS ARE EXPOSED. DO NOT REVERSE THE HOT AND NEUTRAL CONNECTIONS OR SAFETY WILL BE COMPROMISED.
11. GENTLY TUCK THE WIRE CONNECTIONS NEATLY INTO THE CEILING JUNCTION BOX.
12. ATTACH THE MOUNTING PLATE (A) WITH NIPPLE TO THE CEILING OUTLET BOX USING THE ENCLOSED MOUNTING SCREWS (J) AND TIGHTEN SCREWS WITH A SCREWDRIVER.
13. PUSH COLLAR LOOP IN CANOPY (B) AND THREAD ONTO NIPPLE IN MOUNTING PLATE (A) BY TURNING CLOCKWISE.
14. SCREW ROD (C1) TO CANOPY (B), USING HEXANGULAR SET SCREW AND ALLEN WRENCH(K) BE SURE ALL THE HEXANGULAR SET SCREWS ARE TIGHT.
15. GENTLY INSERT THE GLASS TUBE(H) INTO GROOVE INNER THE BIG RING AS FIG 1. REPEAT THE SAME OPERATION ON THE REMAINING 231PCS GLASS TUBES ONE BY ONE.
16. INSERT 12 TYPE A 100W BULBS (OR SUITABLE CFL 26/LED 20W, NOT INCLUDED) INTO THE SOCKETS. DO NOT EXCEED SPECIFIED WATTAGE.

CARE INSTRUCTIONS:

Wipe with a soft, dry cloth. To protect finish, avoid the use of chemicals and household cleaners.

For customer service questions call 1-800-338-2150

ARTERIO RS