

ASSEMBLY INSTRUCTIONS

ITEM DESCRIPTION:

ITEM NO.: DWC19 NAME: Yesenia Sconce
 MATERIAL TYPE: Steel&Poly FINISH: EBN&Greystone
 SOCKET TYPE: LED COB SOCKET QTY: _____
 BULB WATTAGE: 4W Dimmable VOLATGE: 110V-120V
 ITEM NET WEIGHT: 6.8lbs

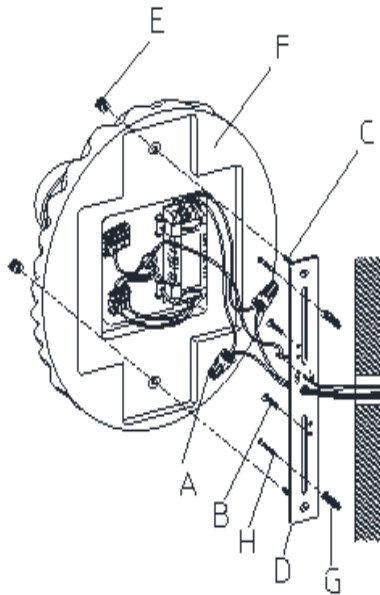

PARTS INCLUDED:

| | |
|--------------------|-----------|
| MOUNTING BAR(D): | QTY: 1 PC |
| MOUNTING BEAD (E): | QTY:2 PCS |
| BACK PLATE(F): | QTY: 1 PC |

HARDWARE INCLUDED:

| | |
|------------------------|-----------|
| Plastic Wire Cap(A) | QTY:3 PCS |
| Mounting Screw (B): | QTY:3 PCS |
| Pre-mounted Screw (C): | QTY:3 PCS |
| Anchor(G): | QTY:3 PCS |
| Strengthened Screw(H) | QTY:3PCS |

TOOLS NEEDED (NOT INCLUDED):

1 SCREWDRIVER

These instructions are provided for safety. It is very important that they are read carefully and completely before beginning installation of this chandelier.

We strongly suggest that all hard wired fixtures must be installed by a professional electrician.

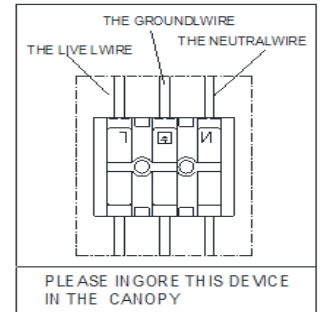

TO ASSEMBLE:

1. Shut off the main electrical supply from the main fuse box/ circuit breaker
2. Drill the **anchor(G)** to the wall first, attach the **mounting bar(D)** to the junction box using **mounting screws(B)**. Tighten using screwdriver, then screw the **strengthened screws(H)** into the anchors.
3. Connect ground wire from wall to ground wire from lamp using **wire caps(A)**.
4. Attach house wire to lamp wires as shown. Fasten the pairs together with a wire cap
DO NOT REVERSE THE HOT AND NEUTRAL CONNECTIONS OR SAFETY WILL BE COMPROMISED.
5. Attach **back plate(F)** to mounting bar by passing through **pre-mounted screws(C)** and tighten with mounting beads(E).
6. Restore power to junction box and test fixture.

CATUION:

The light source in this luminaire shall only be replaced by the manufacture or his service agent or a similar qualified person.

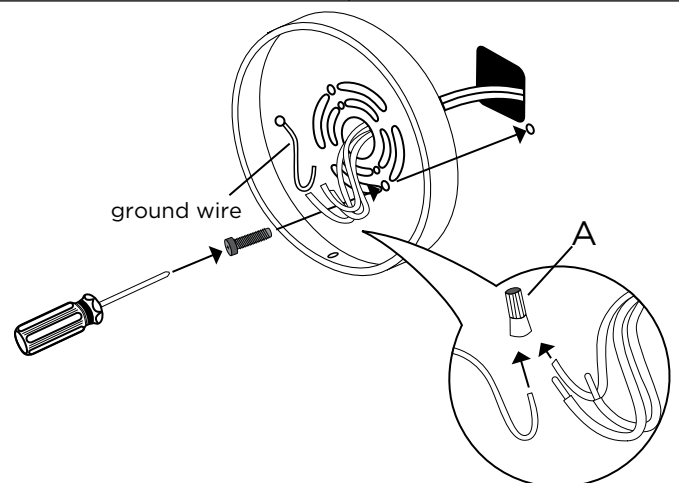
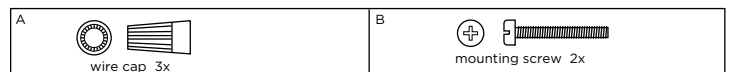

CARE INSTRUCTIONS:

Wipe with a soft, dry cloth. To protect finish, avoid the use of chemicals and household cleaners.