

# ASSEMBLY INSTRUCTIONS

## ITEM DESCRIPTION:

ITEM NO.: DWI19                      NAME: Chamberlin Sconce

MATERIAL TYPE: Glass              FINISH: Smoke Luster

SOCKET TYPE: E12 TYPE B        SOCKET QTY: 02

BULB WATTAGE: 25 W

VOLTAGE: 125V                      ITEM NET WEIGHT: 4 LBS



## TO ASSEMBLE:

1. Shut off the main electrical supply from the main fuse box/circuit breaker.
2. Attach mounting plate to wall or junction box using mounting screws (C).
3. Connect ground wire from wall to ground wire from lamp using wire caps (A).
4. Attach house wire to lamp wires as shown. Fasten the pairs together with a wire caps. **DO NOT REVERSE THE HOT AND NEUTRAL CONNECTIONS OR SAFETY WILL BE COMPROMISED.**
5. Attach front face of light to back plate by inserting canopy screws (B) through predrilled holes in front face and into back plate as shown. Tighten using screwdriver.
6. Fix the Glass Shades on the Socket by tightening with the Metal Shade Rings provided
7. Insert (2) **TYPE B 25W BULB / 7W SBCFL / 5 W SBLED** (not included) into the socket. **DO NOT EXCEED SPECIFIED WATTAGE**
8. Restore power to junction box and test fixture.

## PARTS INCLUDED:

Mounting Plate	Qty:	1
Back Plate	Qty:	1
Glass Shade	Qty:	2
Metal Shade Ring	Qty:	2

## HARDWARE INCLUDED:

Mounting Screws	Qty:	02
Plastic Wire Connector	Qty:	02
Canopy Screw	Qty:	03

## TOOLS NEEDED (Not Included):

1 Screwdriver

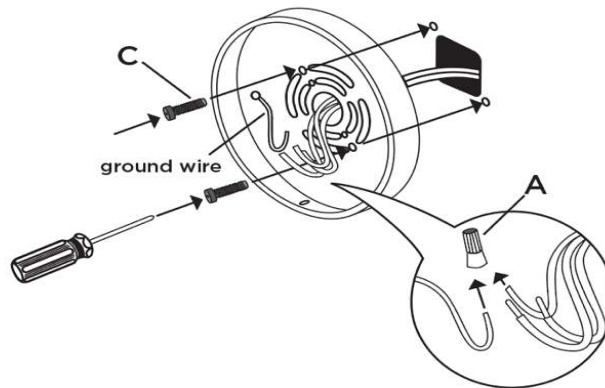

## CARE INSTRUCTIONS:

Wipe with a soft, dry cloth. To protect finish, avoid the use of chemicals and household cleaners.

For customer service questions call 1-800-338-2150

A R T E R I O R S