

# ASSEMBLY INSTRUCTIONS

## ITEM DESCRIPTION:

ITEM NO.: 49842	NAME: Maisie Sconce
MATERIAL TYPE: Crystal	FINISH: Clear
SOCKET TYPE: Integrated LED	SOCKET QTY: 2
BULB WATTAGE: 9W	
VOLTAGE: 110-120 V	ITEM NET WEIGHT: 8 LBS

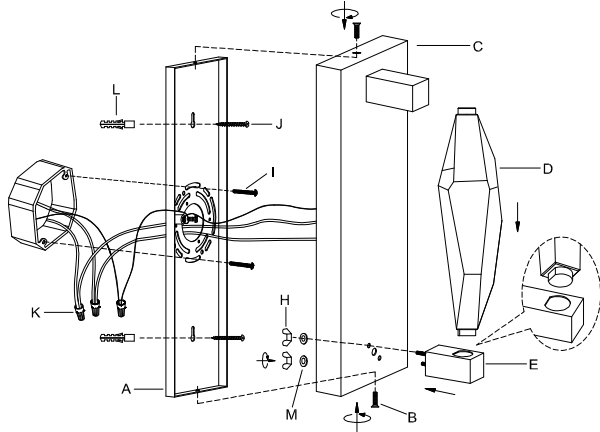

## PARTS INCLUDED:

Mounting Plate ( A )	Qty: 1 Pc
Screws ( B )	Qty: 2 Pcs
Lamp Body ( C )	Qty: 1 Pc
Crystal ( D )	Qty: 1 Pc
Metal Part ( E )	Qty: 1 Pc
Butterfly Nut ( H )	Qty: 2 Pcs
Metal Washer ( M )	Qty: 2 Pcs

## HARDWARE INCLUDED:

Mounting Screws ( I )	Qty: 2 Pcs
Strengthen Screw ( J )	Qty: 2 Pcs
Plastic Wire Connector ( K )	Qty: 3 Pcs
Anchor ( L )	Qty: 2 Pcs

## TOOLS NEEDED (Not Included):

1 Screwdriver

These instructions are provided for safety. It is very important that they are read carefully and completely before beginning installation.

We strongly suggest that all hard-wired fixtures must be installed by a professional electrician.



## TO ASSEMBLE:

1. Shut off the main electrical supply from the main fuse box/circuit breaker.
2. Pull the electrical cord from the canopy through the exit hole of the mounting plate (A)
3. Drill two holes in the wall in line with the two holes of the mounting plate (A), insert anchors (L) into drilled holes. Fasten mounting plate (A) to the wall by screwing the two strengthen screws (J) provided in the anchors (L). YOU DO NOT NEED TO CONNECT THE TERMINAL BLOCK. IT IS USED FOR THE WIRE CONNECTION FOR THE EURO-MARKET.
4. Carefully inspect the fixture wires. The neutral fixture wire has very fine ridges molded into its plastic covering. The hot fixture wire has a smooth covering. The bare silver wire is the ground wire.
5. Attach the ground wire from the fixture to the ground junction box wire from the outlet (usually green or bare wire) fasten each together with a plastic wire connector (K) and wrap the connection with electrical tape. If your outlet box does not have a ground wire, insert the green ground screw into the mounting plate (A) facing down, and wrap the fixture's bare ground wire around the ground screw. IT IS IMPERATIVE THAT THE OUTLET BOX IN YOUR HOME BE PROPERLY GROUNDED.
6. Connect the neutral fixture wire to the neutral junction box wire (usually white). Fasten each together with a wire connector (K) and wrap the connection with electrical tape. Be sure no strands are exposed.
7. Connect the hot fixture wire to the hot junction box wire (usually black). Fasten each together with a plastic wire connector (K) and wrap the connection with electrical tape. Be sure no wire strands are exposed. DO NOT REVERSE THE HOT AND NEUTRAL CONNECTIONS OR SAFETY WILL BE COMPROMISED.
8. Gently tuck the wire connections neatly into the junction box.
9. Attach the mounting plate (A) to the outlet box by using the mounting screws (J), and tighten it with a screwdriver.
10. Insert the bottom of the crystal (D) into the metal part (E) and insert the screw of the metal part (E) into the two holes on the lamp body (C), then insert the top of the crystal (D) into the lamp body (C). Then, secure the metal part (E) and crystal (D) by turning the butterfly nut (H) and metal washer (M) in a clockwise direction.
11. Attach the back plate to the mounting plate (A) by using the enclosed screws (B) and tighten the screws with a screwdriver.
12. Restore power to junction box and test fixture. DO NOT EXCEED

## CARE INSTRUCTIONS:

Wipe with a soft, dry cloth. To protect finish, avoid the use of chemicals and household cleaners.

For customer service questions call 1-800-338-2150

ARTERIOS