



Roto Flush

BY

minkaAire[®]
A Minka Group[®] Co.

INSTRUCTION MANUAL WARRANTY CERTIFICATE



The Minka-Aire® warranty is for one (1) year from the date of purchase from an authorized Minka-Aire® dealer. This warranty is only valid to the original purchaser or user against all defects in material and workmanship (light bulbs excluded) for one (1) full year. Additionally, Minka-Aire® warrants the motor only for the lifetime of the Minka Aire ceiling fan (excluding wall controls and electrical components), to the original purchaser or user.

- * The warranty is voided with the use of any non- Minka-Aire® electrical devices, e.g., wall controls or electrical dimmer switches, etc...
- * The warranty is void once the original purchaser or user ceases to own the fan or the fan is moved from its original point of installation.
- * The warranty is void with the use of any hanger bracket (non-Minka Aire or non-fan specific) other than the hanger bracket supplied & installed with this specific fan.

Warranty Service Information

To obtain warranty service during the warranty period, the purchaser should return the fan with the sales receipt to the original place of purchase. The authorized Minka-Aire® dealer, at its sole discretion, will either repair or replace the fan after verifying the legitimacy of the warranty claim. Replacement is subject to availability of the same model. If the model is unavailable it will be replaced by one of equal value. This is a limited warranty; the original purchaser or user is responsible for the cost of removal and reinstallation of repaired or replacement product.

To obtain the name of the Minka-Aire® authorized dealer nearest you call the Minka-Aire® customer care department at 1-800-307-3267, or contact Minka-Aire® through www.minkagroup.net and select FAQ to answer any questions or if you require additional assistance submit the question form found there.

Date Purchased _____

Store Purchased _____

Model Number F644L

CONTENTS

SAFETY RULES.....	1	INSTALLING THE FAN HOUSING	7
PACKAGE CONTENTS.....	2	ATTACHING THE FLYWHEEL AND FAN BLADES	8
INSTALLING THE MOUNTING BRACKET.....	3	INSTALLING THE 16W LED ASSEMBLY	9
HANGING THE FAN TO THE MOUNTING BRACKET.....	4	FAN WITHOUT LED (OPTIONAL)	10
MAKING THE ELECTRICAL CONNECTIONS	5	OPERATING THE REMOTE CONTROL/WALL CONTROL.....	11
HANGING THE FAN MOTOR ASSEMBLY	6	CARE OF YOUR FAN	12
		TROUBLESHOOTING.....	13
		SPECIFICATIONS.....	14



1151 W. Bradford Court, Corona, CA 92882 • For Customer Assistance Call: 1-800-307-3267



1

SAFETY RULES

1. Before you begin installing the fan, shut power off the circuit breaker of the fuse box.
2. Be cautious! Read all instructions and safety information before installing your new fan. Review accompanying assembly diagrams.
3. Make sure that all electrical connections comply with local codes, ordinance, or National Electrical Codes, ANSI/NFPA 70. Hire a qualified electrician or consult a do-it-your self wiring handbook if you are unfamiliar with installing electrical wiring.
4. Make sure the installation site you choose allows the fan blades to rotate without any obstructions. Allow a minimum clearance of 7 feet from the floor and 18 inches from the top of the blades to the wall.
5. If you are mounting the fan to a ceiling fan outlet box, use a U.L Listed metal octagonal outlet box marked "Acceptable For Fan Support". Secure the box directly to the building structure. The outlet box and its support must be able to support the moving weight of the fan (at least 50 pounds). Do not use a plastic box.
6. Caution: To reduce the risk of injury use only the screws provided with the outlet box in conjunction with the lock washers provided with the fan.
7. If you are mounting the fan to a joist, make sure it is able to support the moving weight of the fan (at least 50 pounds).
8. After you install the fan, make sure that all mounting components are secured to prevent the fan from falling.
9. Do not insert anything into the fan blades while the fan is operating.

NOTE: The important safeguards and instructions appearing in this manual are not meant to cover all possible conditions and situations that may occur. It must be understood that common sense, caution and care are factors which can not be built into this product. These factors must be supplied by the person(s) installing, caring for and operating the unit.

NOTE: READ AND SAVE ALL INSTRUCTIONS!

WARNING

TO REDUCE THE RISK OF FIRE, ELECTRIC SHOCK OR OTHER PERSONAL INJURY, MOUNT FAN ONLY TO A U.L LISTED OUTLET BOX OR SUPPORTING SYSTEM MARKED ACCEPTABLE FOR FAN SUPPORT AND USE MOUNTING SCREWS PROVIDED WITH THE OUTLET BOX IN CONJUNCTION WITH THE LOCK WASHERS PROVIDED WITH THE FAN. MOST OUTLET BOXS COMMONLY USED FOR FAN SUPPORT OF LIGHTING FIXTURES ARE NOT ACCEPTABLE FOR FAN SUPPORT AND NEED TO BE REPLACED. CONSULT A QUALIFIED ELECTRICIAN IF IN DOUBT.

TO REDUCE THE RISK OF PERSONAL INJURY, DO NOT BEND THE BLADE HOLDERS WHILE INSTALLING BALANCING THE BLADES OR CLEANING THE FAN. DO NOT INSERT FOREIGN OBJECTS BETWEEN ROTATING FAN BLADES.

TO REDUCE THE RISK OF FIRE OR ELECTRIC SHOCK, THIS FAN ONLY CAN USE DL-1167RYS-02 SOLID-STATE SPEED CONTROL WITH DL-4111G-01 REMOTE CONTROL ONLY.

2

PACKAGE CONTENTS

Unpack your fan and check the contents. You should have the following items:

1. Fan blades(3)
2. Mounting bracket
3. Receiver (Pre-assembled inside the mounting plate)
4. Fan motor assembly
5. Fan housing
6. Flywheel
7. 16W LED assembly
8. Metal shade
9. Transmitter + holder + 2 mounting screws + A23 12 volt battery
10. Balancing kit

- A. Mounting hardware:
Wire nuts(3)
#8x3/4" Machine screws (2)
#10x1.5" Wood screws (2)
Star washers (2)
Metal washers (2)
Lock washers (2)
- B. Blade attachment hardware:
3/16" x 12.7mm blade screws (9 + 1 spare)
Fiber washers (9 + 1 spare)
- C. Flywheel attachment hardware:
1/4" x 10.5mm flywheel screws (5 + 1 spare)

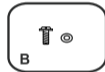
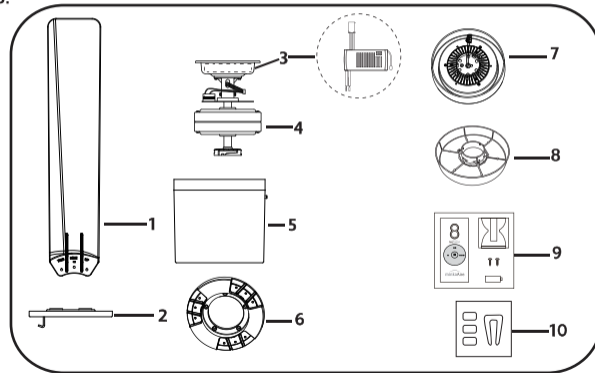

INSTALLING THE MOUNTING BRACKET

Installing the mounting bracket to the electrical box

WARNING: To reduce the risk of fire, electric shock or other personal injury, mount the fan only to an outlet box or supporting system marked acceptable for fan support and use the mounting screws provided with the outlet box.

Step 1. Place the slots from the mounting bracket over the two mounting screws provided with the outlet box. (Fig.1)

Step 2. Slide the mounting bracket until it locks in place at the narrow section of the slots. (Fig.1)

Step 3. Securely tighten the two mounting screws provided with the outlet box. (Fig.1)

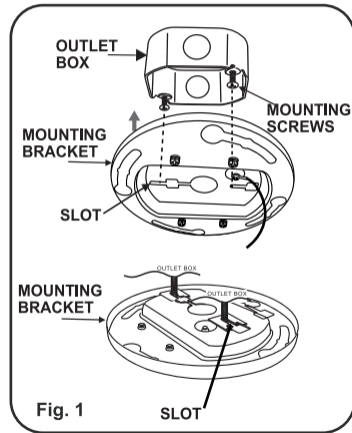

4

HANGING THE FAN TO THE MOUNTING BRACKET

Step 1. Remove the mounting plate screw from the mounting bracket and loosen the other three mounting plate screws approximately 1/4 turn. Place the mounting plate screw that was removed aside for use later. (Fig.2)

Step 2. Lift the fan motor assembly by hanging the square hole of the mounting plate on the J hook from the mounting bracket allowing it to hang. (Fig.3)

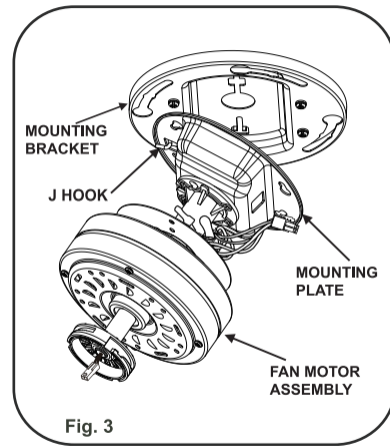
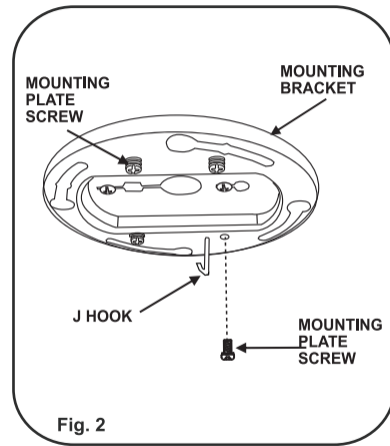

MAKING THE ELECTRICAL CONNECTIONS

WARNING: To avoid possible electrical shock, ensure the electricity is turned off at the circuit breaker or main fuse box before wiring.

WARNING: Check to see that all connections are tight, including the ground, and that no bare wire is visible at the wire nuts, except for the ground wire.

WARNING: The use of Dimming devices not compatible with ceiling fans will cause unwanted behavior including loud humming and will cause permanent damage to you fans electrical component.

Follow the steps below to connect the fan to your house supply wires. Secure the wire nuts supplied with your fan by wrapping the connections with electrical tape.

- Connect the black (hot) wire from the ceiling to the black wire marked "AC in L" from the receiver.
- Connect the white (neutral) wire from the ceiling to the white wire marked "AC in N" from receiver.
- Connect the ground wire (green or bare copper) of the outlet box to the ground wire of the mounting plate and the ground wire of the mounting bracket.
- Secure the wire connection with a plastic wire nut provided with the electrical hardware.
- After connecting the wires, spread them apart so that the green and white wires are on one side of the outlet box and the black wires are on the other side. Carefully tuck the wire connections up into the outlet box.

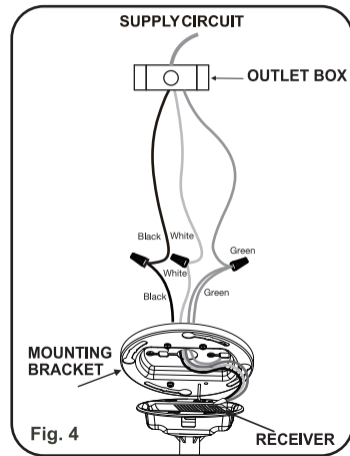

HANGING THE FAN MOTOR ASSEMBLY

Step. 1. Lift and place the key holes on the mounting plate over the three screws previously loosened on the mounting bracket and turn the mounting plate until it locks in place and no longer turns. (Fig.5)

Step 2. Secure by tightening the three screws previously loosened and the screw previously removed. (Fig.6)

WARNING: Ensure you complete this step correctly and follow all steps. Failure to correctly follow this step might cause the fan to fall.

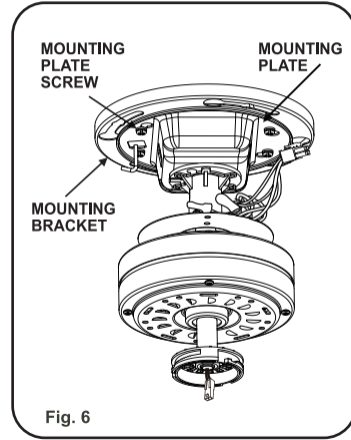
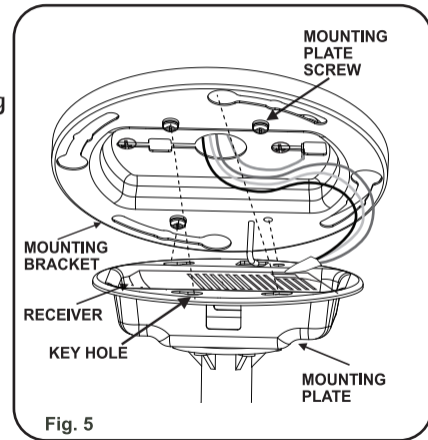

INSTALLING THE FAN HOUSING

7

Step 1. Pay attention to the four large screwheads Pre-locked on the fan housing and the four key holes on the mounting bracket. they will be needed to be locked together after finished the wire connection in previous step. (Fig.7)

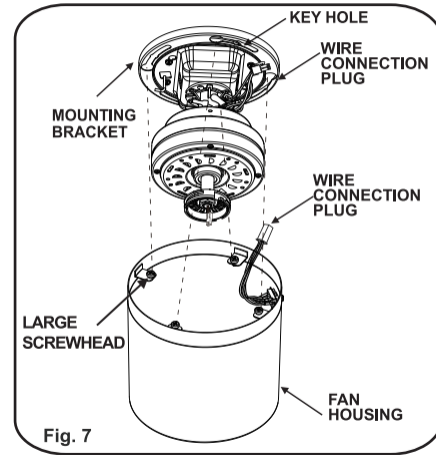

Step 2. Firmly snap the wire connection plug from fan motor assembly to the wire connection plug from fan housing. (Fig.8) Make Sure the wire connections are not in the way of the housing as you lift the housing and proceed to next step.

Step 3. Align the four large screwheads pre-locked on the fan housing to the key holes of the mounting bracket. Turn the fan housing at the right side and twist the screwheads to the end of the slotted holes until they lock in place and no longer turn. (Fig.9)

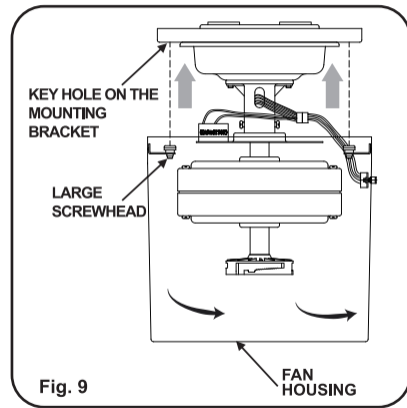
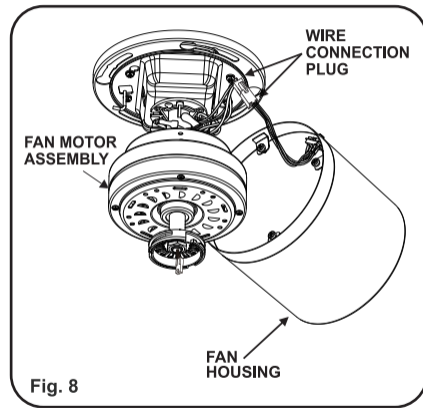

ATTACHING THE FLYWHEEL AND FAN BLADES

Step 1. Pay attention to arrow labels on the motor and the flywheel. Start from this label and align the five holes on the motor to the five holes on the flywheel. Tighten them using with five flywheel screws (1/4" x 10.5mm) securely. (Fig.10)

Step 2. Align the 3 holes from the blade to the flywheel. Secure blade with 3 blade screws (3/16" x 12.7mm) and 3 fiber washers provided. Follow same process for the remaining two blades. (Fig.11)

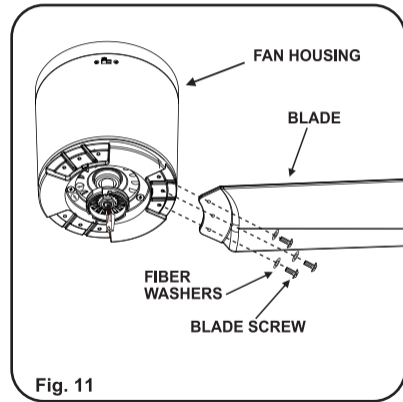
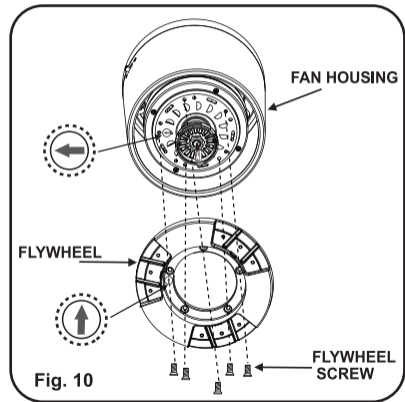

INSTALLING THE 16W LED ASSEMBLY

CAUTION: To reduce the risk of electric shock, Disconnect the electrical supply circuit to the fan before installing the light kit.

Step 1. While holding the 16W LED assembly under your fan, Firmly snap the wire connection plugs together. (Fig.12)

Step 2. Attach the 16W LED assembly to the switch box by twisting tightly. (Fig.12)

NOTE: This is an integrated LED light kit assembly and can not be disassembled to prevent electronic shock.

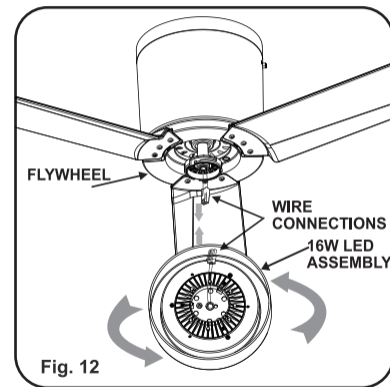

FAN WITHOUT LED (OPTIONAL)

10

NOTE: The metal shade included with your fan is an option to replace the LED assembly in the event that you prefer not to use the light feature of your fan. The metal shade is not necessary for the light operation. It can be saved for later use if desired. (Fig.13)

Raise metal shade up against bottom of fan housing and secure it to fan by turning it clockwise until snug. **DO NOT OVERTIGHTEN.** (Fig. 13)

NOTE: Installing the metal shade. Make sure the metal shade is securely tighten.

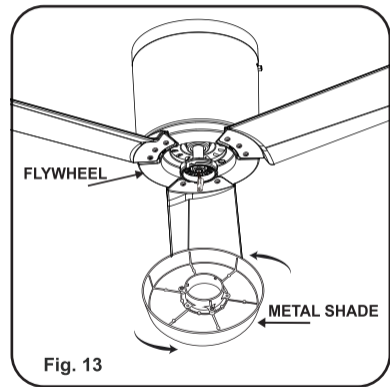

Fig. 13

OPERATING THE REMOTE CONTROL/WALL CONTROL

Remote Control only: Install a A23 12volt battery (included). To prevent damage to transmitter remove the battery if not used for long periods of time.

Restore Power to Ceiling Fan.

A. ● ● ● Buttons:

These buttons are used to set the fan speeds as follows:

- = Low Speed
- ● = Medium Speed
- ● ● = High Speed

B. ■ Button:

This button turns the fan off.



C. ○ Button:

These buttons turn the light ON or OFF and also control the brightness settings of the light. The following

instructions apply to ceiling fans that feature a DOWN light (○ button) only or ceiling fans that feature an UP light (● button) and a DOWN light (○ button) that are controlled independent of each other;

Press and release the button for the desired light to turn the light ON or OFF. Press and hold the button to set the desired light brightness. The light will cycle between bright and dim settings as long as the button is pressed. The light key has an automatic auto-resume feature that allows the light to remain at the same brightness as the last time it was turned off.

D. OFF-ON Slide Button (Wall Control Fans Only)

This button turns the power Off and On to the Fan and Light(s).

E. ↻ Button: (Full Function Remote Control Units Only)

This button is used to change the direction of the rotation of the blades; forward for warm weather or reverse for cool weather.

NOTE: If your Remote Control or Wall Control does not have a "↻" button, Please look for a slide reverse switch on the switch housing.

Speed settings for warm or cool weather depend on factors such as the room size, Ceiling height, number of fans, etc.

The reverse switch is located on the surface of the fan motor assembly. Slide the switch to the left for warm weather operation. Slide the switch to the right for cool weather operation.(Fig. 14)

NOTE: Wait for fan to stop before changing the setting of the slide switch.

Warm Weather(forward)

A **DOWNWARD** airflow creates a cooling effect as shown in Figure 15. This allows you to set your air conditioner on a warmer setting without affecting your comfort.

Cool Weather(Reverse)

An **UPWARD** airflow moves warmer air off the ceiling area as shown in Figure 16. This allows you to set your heating unit on a cooler setting without affecting your comfort.

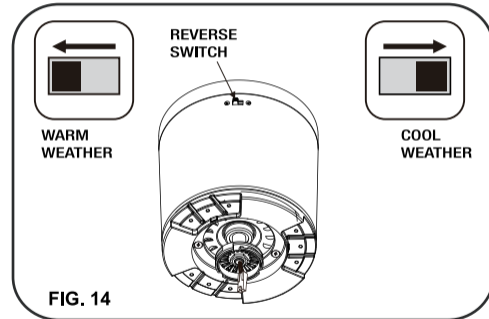

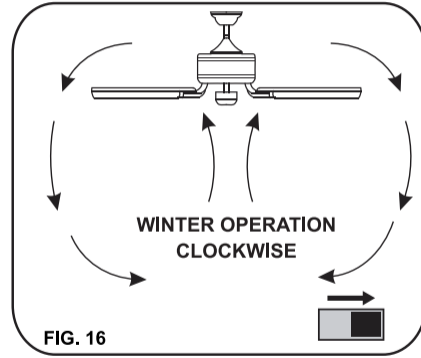
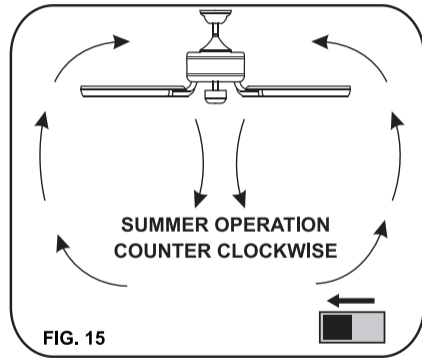

CARE OF YOUR FAN

Here are some suggestions to help maintain your fan.

1. Because of the fan's natural movement some connections may become loose. Check the support connections, brackets and blade attachment twice a year. Make sure they are secure. (It is not necessary to remove fan from the ceiling).

2. Clean your fan periodically to help maintain its new appearance over the years. Use only a soft brush or lint free cloth to avoid scratching the finish. Plated finishes are sealed with lacquer to minimize discoloration or tarnishing.

Do not use water when cleaning, this could damage the motor, wood blades or possibly cause an electrical shock.

3. Use a lint free lightly damp cloth or duster to remove dust from the blades.

4. There is no need to oil your fan. The motor has permanently lubricated bearings.

5. If your fan is provided with glass shades, clean with lukewarm soapy water and a soft cloth or sponge. **DO NOT IMMERSE GLASS SHADES IN HOT WATER. DO NOT PUT GLASS SHADES INTO AN AUTOMATIC DISHWASHER.**

WARNING

MAKE SURE THE POWER IS OFF AT THE ELECTRICAL PANEL BOX BEFORE YOU ATTEMPT ANY REPAIRS. REFER TO THE SECTION "ELECTRICAL CONNECTIONS".

TROUBLESHOOTING

SYMPTOM

Fan will not start

SOLUTION

- Check to make sure the wall switch is turned on.
- Check circuit fuses or breakers.
- Caution! Make sure the power is turned off before performing the following steps.
- Remove canopy and check wire connections.
- Check wall control transmitter connections(if applicable).
- Note:fan must be installed at a maximum distance of 40 feet from the transmitting unit for proper signal transmission between the transmitting unit and the fan's receiving unit.

SYMPTOM

Fan Sounds Noisy

SOLUTION

- Allow a 24 - hour "break in" period. Most noises associated with a new fan will go away during this time.
- Make sure the screws that attach the fan blade holder to the motor hub is tight.
- Make sure outlet box is secured to building structure, if necessary use the wood screws provided to further secure outlet box to joist.
- Make sure hanger bracket is secure to the outlet box,screws are tight.

SYMPTOM

Fan Wobble

SOLUTION

- NOTE: All blade sets are grouped by weight. Because wood and plastic blades vary in density, the fan may wobble even though blades are matched.
- Make sure outlet box is secured to building structure, if necessary use the wood screws provided to further secure outlet box to joist.
- Make sure hanger bracket is secure to the outlet box, screws are tight.
- If a Balancing kit is provided follow the instructions included with the balancing kit to help correct any excessive wobble.

SYMPTOM

Fans/Light Turn on and Off Unexpectedly

SOLUTION

- This is caused by interference. Please see "frequency interference" for step to change the frequency.

SYMPTOM

Frequency Interference

SOLUTION

1. Turn the power off to your ceiling fan.
2. Please use a small size tool to change the frequency settings on the control system.
3. Return power to the unit.

Note: After the AC power is on, do not press any other button on the transmitter before pressing the "Stop" button, doing so will cause the procedure to fail.

4. Within 60 seconds of turning the fan's AC power ON. Press the transmitter's "Stop" button and hold the "Stop" button for 10 seconds.
5. Once the receiver has detected the set frequency, the down light of your fan will blink twice and the fan will begin to rotate for a short period and then shut off.
6. The receiver has now learned the frequency which has been selected on the transmitter. After completing the steps above, you should be able to operate the ceiling fan and light. If the fan is not responding to the transmitter, please turn the power off to the receiver, and repeat the process.

SPECIFICATIONS

These are typical readings. Your actual fan may vary. They do not include amps and wattage used by the light (s).

For any additional information about your Minka Aire® Ceiling fan, please write to:

Fan Size	Speed	Volts	Amps	Watts	RPM	N.W.	G.W.	C.F.
52"	Low	120	0.24	18.41	92	7.13	10.49	1.9'
	High	120	0.38	45.72	163	kgs	kgs	



1151 W. Bradford Court, Corona, CA 92882 • For Customer Assistance Call: 1-800-307-3267

PERFORMANCE AND ENERGY INFORMATION

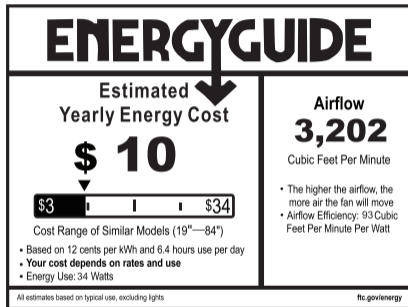

FAN SPEED	AIRFLOW (CFM)*	POWER USE (watts)	AIRFLOW EFFICIENCY (CFM/watt)
Low	2208	18.41	119
High	4078	45.72	89

Ceiling fan airflow is measured in cubic feet per minute (CFM). Power use is measured in watts. To maximize energy savings:

- Choose a fan with high airflow efficiency (CFM/watt).
- Use ENERGY STAR[®]-labeled lighting in your fan.
- Remember to switch off your fan when you leave the room.

* Measured according to the ENERGY STAR[®] approved Solid State test method



For any additional information about your Minka Aire[®] Ceiling fan, please write to:

1151 W. Bradford Court, Corona, CA 92882

• For Customer Assistance Call: 1-800-307-3267