

INSTALLATION INSTRUCTION COLORSCAPING INGROUND

5831



SAFETY INSTRUCTION

IMPORTANT: NEVER attempt any work without shutting off the electricity.

- Read all instructions before installing.
- System is intended for installation by a qualified electrician in accordance with the National Electrical Code and local regulations.
- Place the wall switch in the "OFF" position.
- Go to the main fuse box, or circuit breaker. Unscrew the fuse(s) or switch "OFF" the circuit breaker switch(es) that control the power to the space that you are working on.

CAUTION:

All parts must be used as indicated in these instructions. Do not substitute any parts, leave parts out, or use any parts that are worn out or broken. Failure to follow this instruction could invalidate the UL/cUL listing of this fixture.

AVERTISSEMENT

IMPORTANT : COUPEZ L'ÉLECTRICITÉ AVANT TOUTE MANIPULATION.

- Lisez toutes les instructions avant d'installer.
- Système est destiné à être installé par un électricien qualifié en conformité avec le code national de l'électricité et les règlements locaux.
- Placez l'interrupteur mural en position d'arrêt (« OFF »).
- Accédez au panneau central de disjoncteurs ou de fusibles de votre demeure et placez l'interrupteur principal en position d'arrêt (« OFF »).

MISE EN GARDE

Toutes les pièces doivent être utilisées tel qu'il est indiqué dans ces instructions. Ne remplacez pas les pièces, n'en laissez pas de côté et ne les utilisez pas si elles sont usées ou brisées. Le non-respect de ces instructions peut annuler l'homologation UL du luminaire.

This instruction apply to the model(s) below:

*Note: WAC Smart Transformer is required to power the fixture. (sold separately)

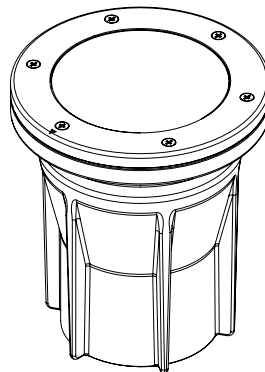

5831

Fixture Accessory (included in box)



Outdoor Rated Wire Nut
Qty: 2pcs

waclighting.com
Phone (800) 526.2588
Fax (800) 526.2585

Headquarters/Eastern Distribution Center
44 Harbor Park Drive
Port Washington, NY 11050

Central Distribution Center
1600 Distribution Ct
Lithia Springs, GA 30122

Western Distribution Center
1750 Archibald Avenue
Ontario, CA 91761

INSTALLATION INSTRUCTION COLORSCAPING INGROUND

5831



CONCRETE POUR INSTALLATION

1. Turn the main power off.
2. Install wiring and conduit (use 1/2" NPT) with Concrete Pour Canister at desired position, plug all un-used holes (Fig. 1) Secure the canister to the bottom of the application ground by using screws.
Note: For proper alignment, make sure the flat edge of the canister is parallel to the wall. (Fig. 2)
3. Insert Plastic Cap into Concrete Pour Canister (Fig. 1)
4. Pour concrete until it's flushed with the Plastic Cap. (Fig. 3)
Note: NO CONCRETE ENTERS THE BOX. USE SAND OR GRAVEL FOR PROPER DRAINAGE.
5. After concrete has cured, crack concrete and remove Plastic Cap using a corkscrew or similar tool. (Fig. 4)
6. Connect fixture leads to box wiring using supplied outdoor rated wire nuts. Make sure all power is off while wiring LED fixture.
7. Apply a smear of plumber's silicone to O-rings. Insert LED fixture into flange with a twisting motion. Make sure the trim is flushed with the top of the poured concrete.
8. To match different height requirements, use extenders and cover plates. (Fig. 5)

Fig.1

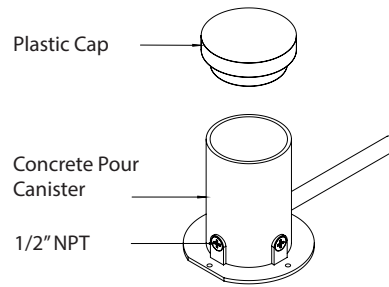

Fig.2

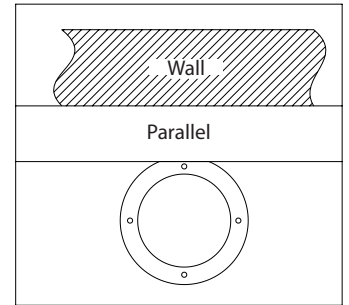

Fig.3

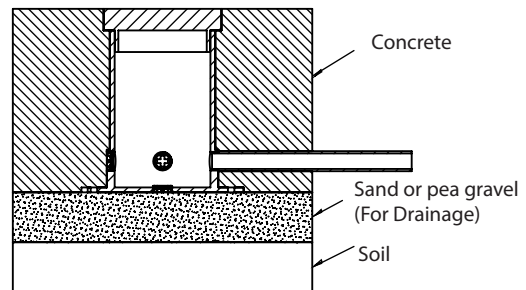

Fig.4

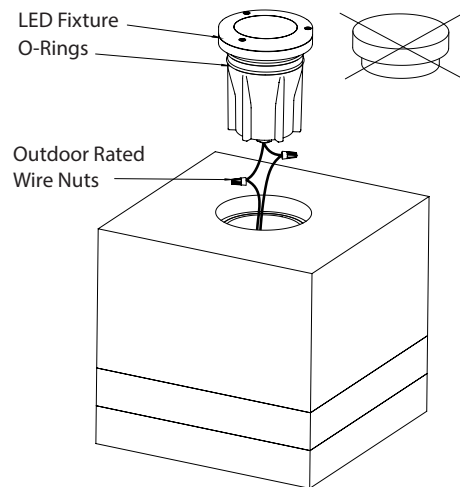
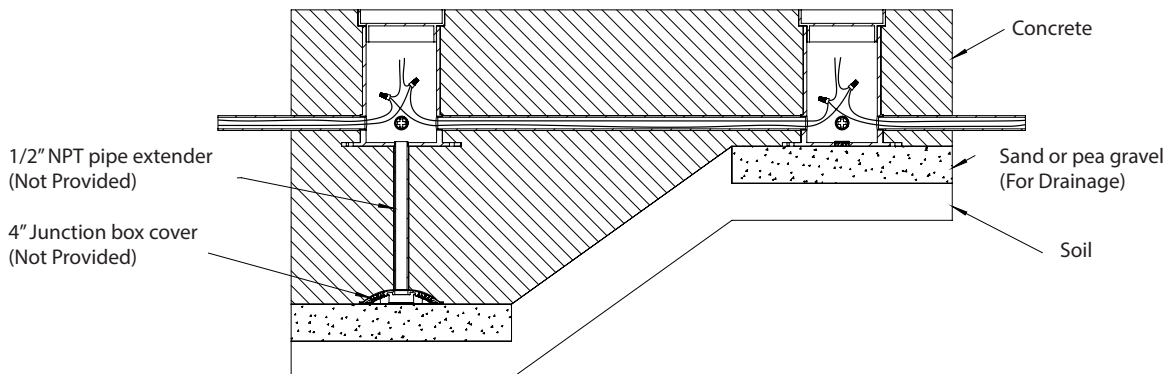

Fig.5



waclighting.com
Phone (800) 526.2588
Fax (800) 526.2585

Headquarters/Eastern Distribution Center
44 Harbor Park Drive
Port Washington, NY 11050

Central Distribution Center
1600 Distribution Ct
Lithia Springs, GA 30122

Western Distribution Center
1750 Archibald Avenue
Ontario, CA 91761

INSTALLATION INSTRUCTION COLORSCAPING INGROUND

5831



SOFTSCAPE INSTALLATION

1. Turn the main power off.
2. Dig a hole at the point of application. Make sure the hole measures at least 4-3/4 inches in diameter and 10 inches in depth. **(Fig.6)**
3. Place a layer of pea gravel (3 inches) at the base of the hole to help with drainage.
4. Connect the fixture wires to landscape wires coming from the transformer using the outdoor rated direct burial wire nuts provided.
5. Place the fixture in the hole and repack the soil to hold it in place. Make sure the trim is flush with the ground.

Fig.6

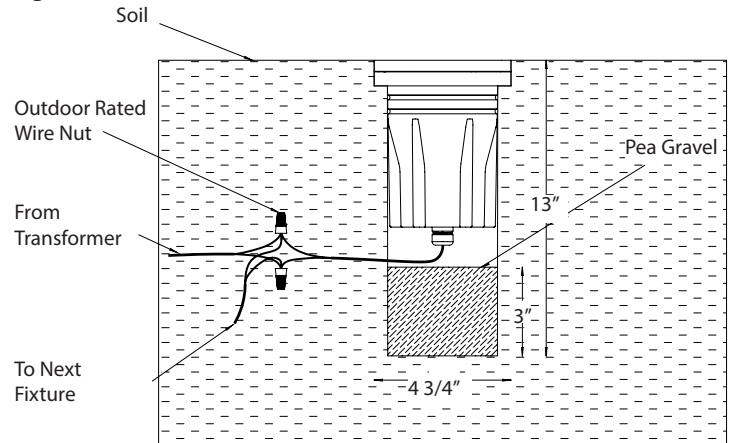

CUSTOMIZE SETTING

This fixture is equipped with two customizable settings: Beam Angle Adjustment, and Beam Aiming Adjustment. It can be pre-set into desired settings by taking the light engine assembly out from the fixture housing. **(Fig. 7)**

1. Unscrew Face Plate Screws with hex L-key.
2. Take out the Face Plate, Gasket, Front Glass
3. Pull the Light Engine out of the Fixture housing.

Note: Light Engine can be taken out remotely by disconnecting the Quick Connector. Users can later reconnect it back into the housing after all desired settings are been made.

To ensure IP67 rating of the fixture, use a minimum force of 2.5 N*M/22 lbf.in to tighten the screws of the face plate.

Fig.7

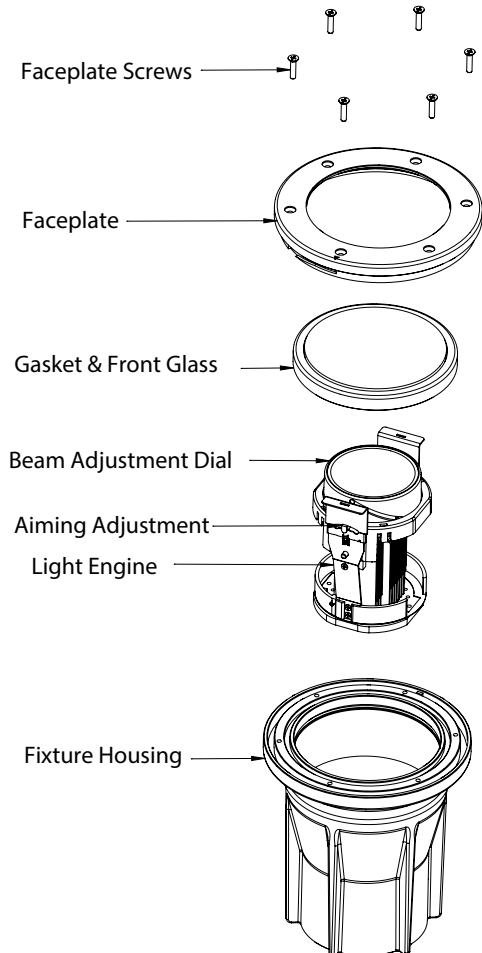

waclighting.com
Phone (800) 526.2588
Fax (800) 526.2585

Headquarters/Eastern Distribution Center
44 Harbor Park Drive
Port Washington, NY 11050

Central Distribution Center
1600 Distribution Ct
Lithia Springs, GA 30122

Western Distribution Center
1750 Archibald Avenue
Ontario, CA 91761

INSTALLATION INSTRUCTION COLORSCAPING INGROUND

5831



BEAM ANGLE ADJUSTMENT:

1. Rotate the Beam Changing Dial to adjust the beam angle with two fingers.
2. The Optical Lens Assembly will move vertically up and down as you rotate the Beam Changing Dial

Fig.8

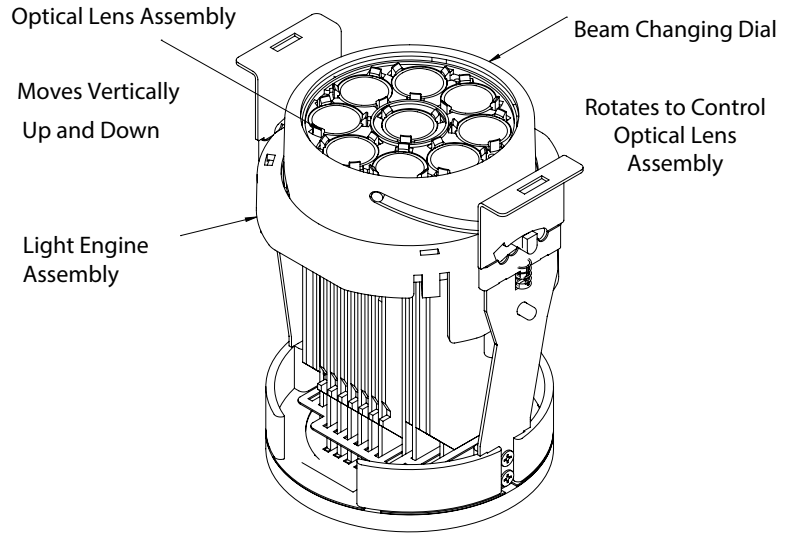

AIMING ADJUSTMENT:

1. Hold the Lens Assembly with two fingers and tilt it left or right as required. (Fig. 9)
2. Lens Assembly will be fixed by a spring mechanism to the desired angle full stop.

Fig.9

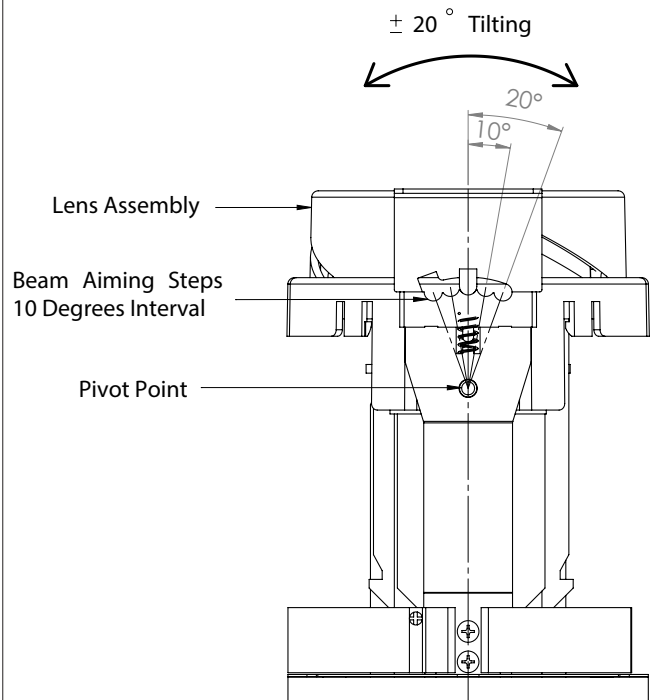

INSTALLATION INSTRUCTION COLORSCAPING INGROUND

5831



ACCESSORIES:

- *Rock Guard* – Protects fixture front glass from large falling objects.

To Install (Fig. 10):

1. Unscrew the Face Plate Mounting Screws.
2. Put the Rock Guard on top of the fixture face plate, make sure to match up the mounting index arrow on the fixture and rock guard.
3. Use the same Face Plate Mounting Screws to mount the Rock Guard onto the fixture.

Fig.10

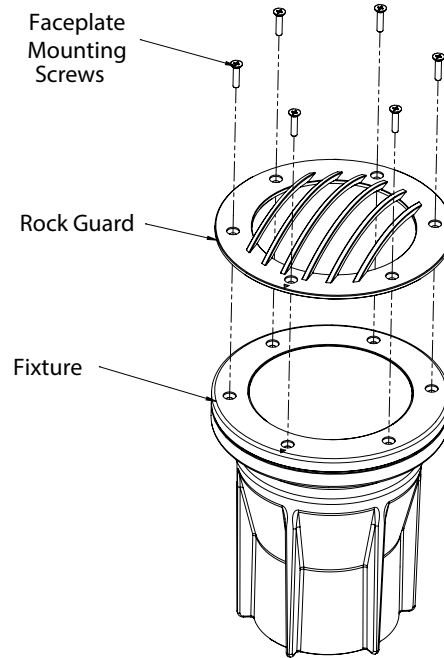

- *Concrete Pour Canister & Cap* – used to install fixture in concrete pour applications.

To install (Fig. 11):

Please visit the previous Concrete Pour Installation instructions.

Fig.11

