

Collection: AXIS

Product #: PLB0060-07

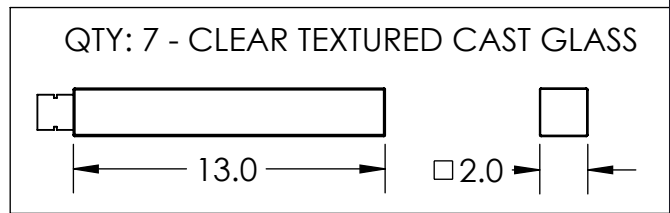
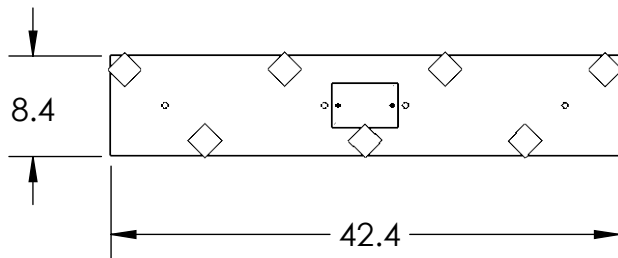
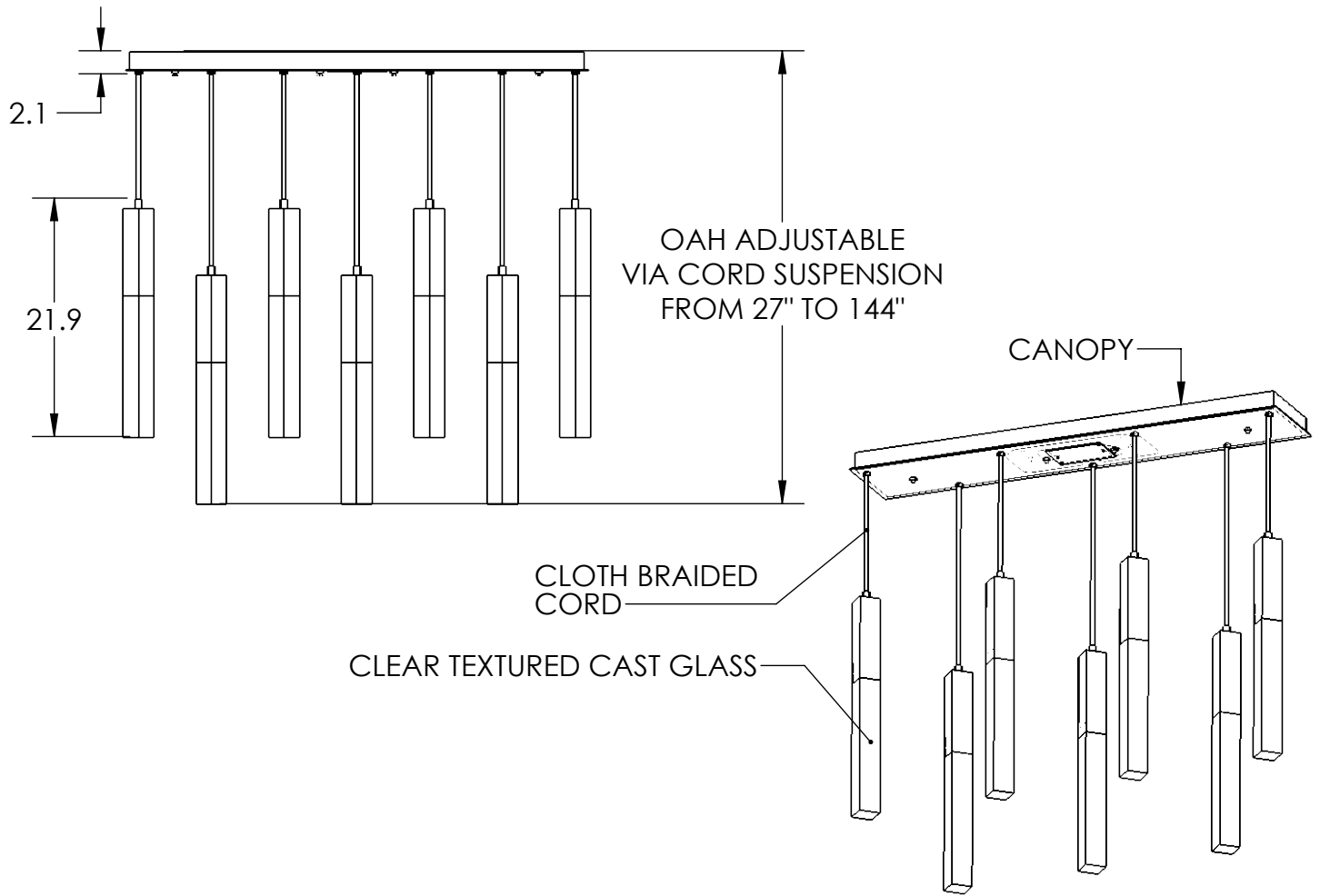

ALL DIMENSIONS ARE IN INCHES UNLESS OTHERWISE STATED  
 Visit [hammertonstudio.com](http://hammertonstudio.com) for product options and specifications.

7/29/2021 (B)

Mounting Packet: R	Weight(lbs.): 68	Electrical Type: LED	CCT: 2700/3000 K
UL Location: DRY		Elec. Qty: 7	Wattage: 27 Voltage: 120
Finish: SEE WEB SITE FOR OPTIONS		Source Lumens: Ambient: 2942	Down: 0
Top Diffuser: N/A		Dimmable: Forward/Reverse Phase To 1%	
Bottom Diffuser: CAST GLASS	CRI: 93+	Power Factor: >0.9	

Mounting Detail

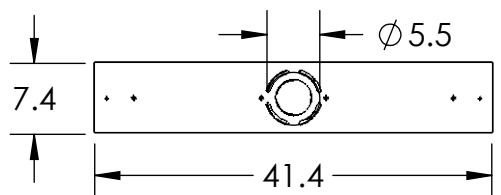

All fixtures created by Hammerton are handcrafted by artisans. Dimensions may vary up to 7/8".  
 © Copyright 2021. All rights in design, detail or invention of this drawing are reserved as the property of Hammerton. Any imitation or adaptation without written consent is strictly prohibited.