

All dimensions are shown in inches unless otherwise stated.

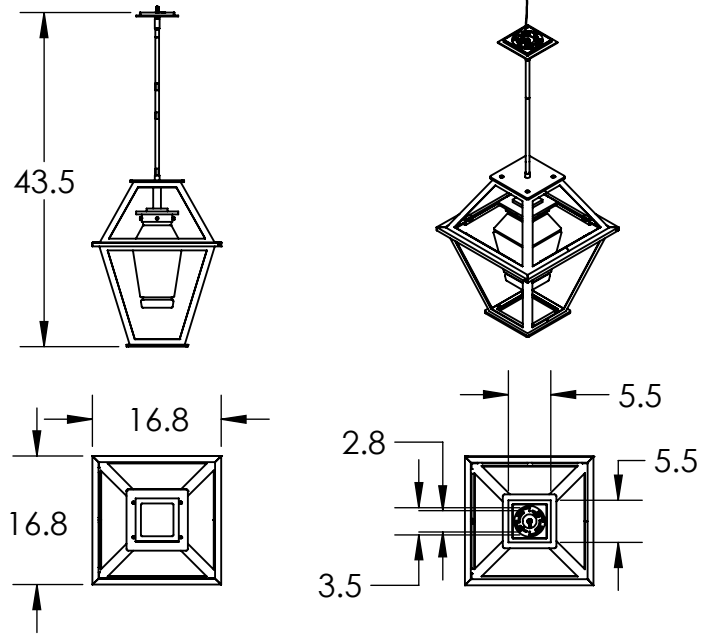

Mounting Method: Mounts Directly to J-Box

**PRODUCT DESCRIPTION**

A classic look that suits a broad range of transitional and traditional architectural styles, this oversized pendant design features a metal outer frame with seeded glass and an interior diffuser in hand blown glass. It is offered with a choice of incandescent and AC LED lamping.

The Terrace Nested Lantern Pendant is offered in three AAMA 2604-rated finishes and includes a lifetime warranty to the original purchaser.

**PRODUCT SPECIFICATION**

*Bulbs Not Included*

Construction: Aluminum Body With Glass Panes and Blown Glass

Finish Options: **AG** **SB** **TB**

Glass Types: **C5**

Suspension Method: Ceiling Mount

Weight(lbs.): 25

UL Rating: Wet

Top Diffuser: Closed Metal

Bottom Diffuser: Closed Glass

Light Source: Incandescent

Bulb Qty: 1

Wattage (Watts):75

Voltage (Volts): 120

Bulb Type: A

Socket Type: Medium, E26

Driver Quantity & Location: 0

SCAN FOR MORE INFORMATION

Notes:

**GENERAL NOTES:**

Visit [studio.hammerton.com](http://studio.hammerton.com) to read about our Lifetime Limited Warranty.

All Hammerton fixtures are handcrafted by artisans. Subtle imperfections reflect the mark of the artisan and should be expected in any handcrafted product. Dimensions may vary up to 7/8".

Rev (B) 6/21/2021