

Collection: PARALLEL GLASS

Product #: PLB0042-07

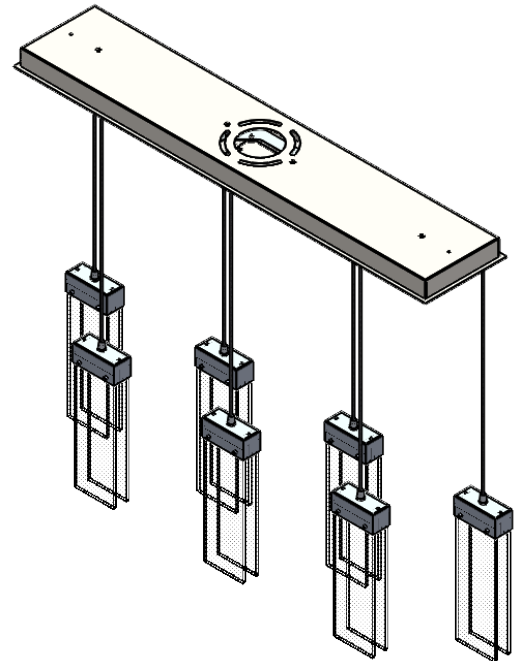
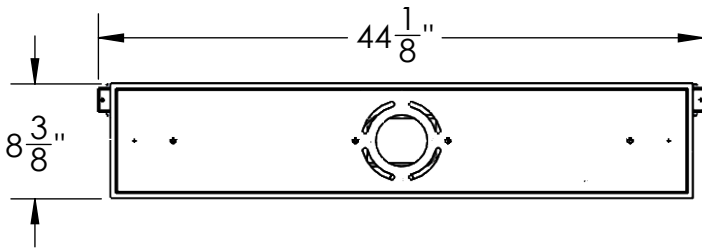
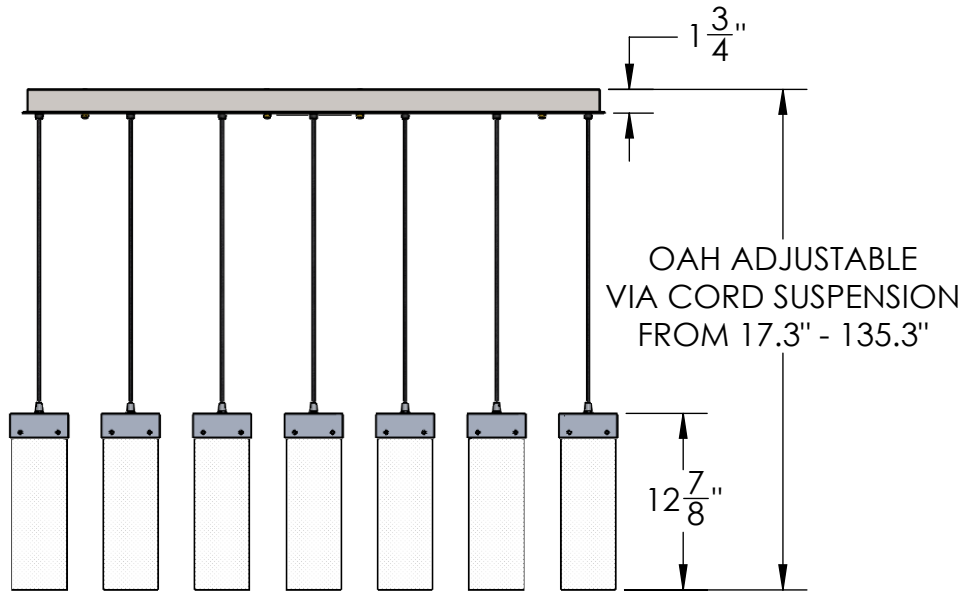

Visit [hammertonstudio.com](http://hammertonstudio.com) for product options and specifications.

7/23/2021 (B)

Mounting Packet: R	Weight(lbs.): 43	Electrical Type: LED	CCT: 2700/3000 K
UL Location: DRY		Elec. Qty: 7	Wattage: 36
Finish: SEE WEB SITE FOR OPTIONS		Source Lumens: Up: N/A	Down: 2395
Top Diffuser: CLOSED		Forward/Reverse Phase or 0-10V To 1%	
Bottom Diffuser: FROSTED GLASS		CRI: 90+	Power Factor: >0.9

Mounting Detail

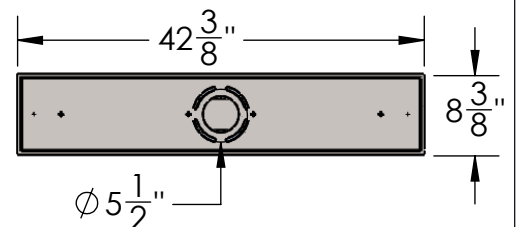

All fixtures created by Hammerton are handcrafted by artisans. Dimensions may vary up to 7/8".  
 © Copyright 2021. All rights in design, detail or invention of this drawing are reserved as the property of Hammerton. Any imitation or adaptation without written consent is strictly prohibited.