

Collection: NOVA (NEBULA)

Product #: CHB0068-09

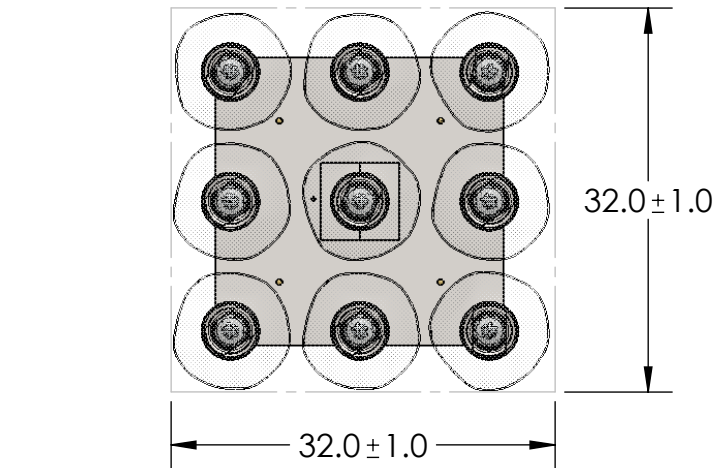

INNER GLASS DIFFUSER OPTIONS QTY: 9	
	Floret HAND-FORMED GLASS
	Geo CAST GLASS
	Zircon CAST GLASS

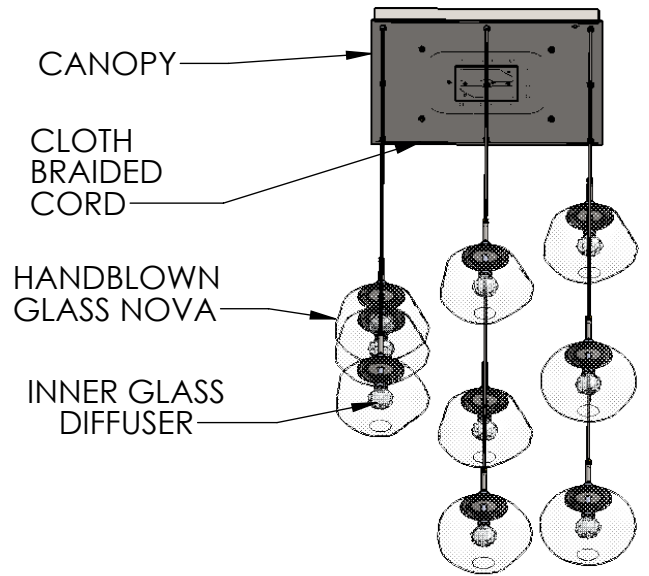
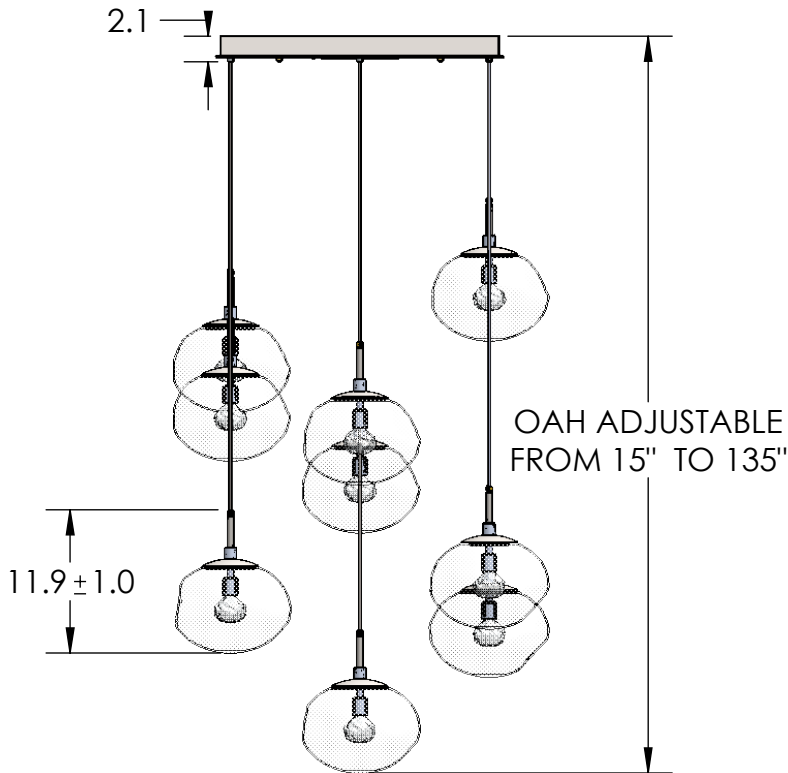
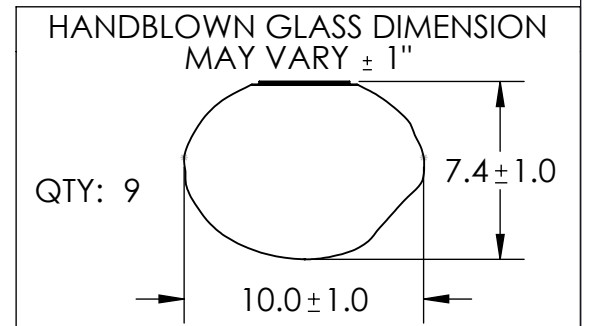

All dimensions are shown in inches unless otherwise stated. Visit hammertonstudio.com for product options.

2/13/2020 (A)

Mounting Packet: R	Weight (lbs.): 90	Electrical Type: LED	CCT: 2700 K
UL Location: DRY		Elec. Qty: 9	Wattage: 47 Voltage: 120
Finish: SEE WEBSITE FOR OPTIONS		Source Lumens: Ambient: 3060	Down: 0
Top Diffuser: N/A		Dimmable: Forward/Reverse Phase To 1%	
Bottom Diffuser: CLOSED GLASS		CRI: 93+	Power Factor: >0.9

All fixtures created by Hammerton are handcrafted by artisans. Dimensions may vary up to 7/8".

© Copyright 2020. All rights in design, detail or invention of this drawing are reserved as the property of Hammerton. Any imitation or adaptation without written consent is strictly prohibited.

Canopy Mounting Detail

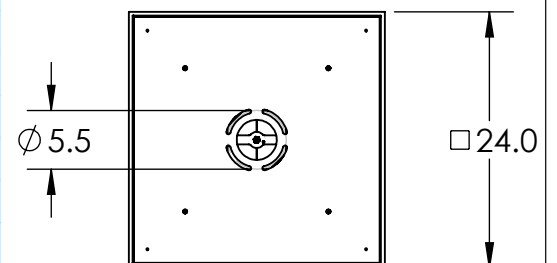

MOUNTS TO BUILDING STRUCTURE