



# REBEL

## MONO & MULTI PORT POINT

DESIGNED BY GREGORY KAY | ASSEMBLED IN AMERICA

REV 10.28.21



**FJ-REB-1-SN**  
Satin Nickel

### DESCRIPTION

The contemporary cylinder-shaped Rebel is a versatile spotlight with a handle that can be removed after hot aiming. It rotates 360° and tilts 90°, performing as either an accent light or a stylish down light. The fixture allows easy re-lamping and holds up to three accessories.

### FINISH & MATERIAL

- Finished in Satin Nickel and White powder coated paint
- Tilt: 90°
- Rotation: 360°

### SYSTEM MOUNTING OPTIONS

For use with any 12VAC Fast Jack Port including Monorail 1 Circuit Rail, MonoPoint canopies 2" or 4" round (RD), and multi-port canopies

### APPLICATION

Suitable for damp or dry location, interior use only

### LAMP SPECIFICATIONS

- Maximum 9 watt LED MR16 lamp GU 5.3 base - 12 volt (sold separately) up to 490 Lumens
- 2700K, 3000K, may be order in warm dim to 1800K

### ACCESSORIES

May take up to 3, 2" round accessories, including glass lens or film lens. Louvers or snoot (see pg 4).

### POWER SUPPLY IN CANOPY

120V input-12VAC output, ELV electric low voltage power supply (FJ, M fixtures order 12VAC power supply separately)

### DIMMING

- Dimmable to 1% Percent of Flicker <25%
- Triac and ELV dimming standard. Compatible with Lutron Diva, Skylark and Legrand ELV dimmers

### COMPLIANCE LABEL

ETL (Conforms to UL1598 and CSA 22.2 #250.0)

### WARRANTY

5 year warranty. See PureEdgeLighting.com



**FJ-REB-1-WH**  
White

System	Fixture	Stem Height	Finish
<b>MP2R</b>	<b>REB</b>	<b>1</b>	<b>SN</b>

<b>FJ</b> Fast Jack	<b>REB</b> Rebel	<b>1</b> 1.2" (2.5cm)	<b>SN</b> Satin Nickel
<b>M</b> Monorail		<b>3</b> 3" (7.62cm)*	<b>WH</b> White
<b>MP2R</b> Mono-Point 2" Round Canopy		<b>6</b> 6" (15.2cm)	
<b>MP4R</b> Mono-Point 4" Round Canopy			
<b>MP4RS</b> Mono-Point 4" Surface Mount Canopy*			
<b>2P4R</b> 2-Port 4" Round Canopy			
<b>3P8R</b> 3-Port 8" Round Canopy			
<b>2P12RE</b> 2-Port 12" Rectangle Canopy			
<b>3P12RE</b> 3-Port 12" Rectangle Canopy			
<b>3P12R</b> 3-Port 12" Round Canopy			

\*Limited quantities, call for availability

PROJECT	FIXTURE TYPE	DATE



**NEW CONSTRUCTION & REMODEL 2" COVER FOR 4" SQUARE JUNCTION BOX**

The New Construction NC2-JBOX Cover is included with the 2" Round and Square Canopies and is not required for the 4" Square Canopies. NC2 New Construction Junction Box Cover mounts to a standard 4" Electrical Box or Octagon Box, converting it to a 2" Plaster Ring for use with the 2R (Round) or 2S (Square) Canopy. The Remodel RM2-JBOX Plaster Plate cover is used with an existing 4" Square Junction Box and standard Round Plaster Ring. The PS-60L-ELV-24VDC (50 Watt IC, 60 Watt Non-IC) will fit inside the NC2 or RM2-JBOX Cover and Electrical Junction Box for a flush look.

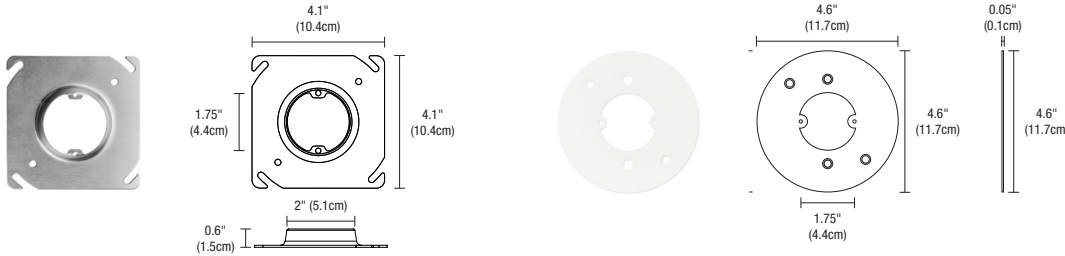

System	Product
<b>NC2</b>	<b>JBOX</b>
NC2 New Construction 2"	JBOX Junction Box
RM2 Remodel Plaster Plate	

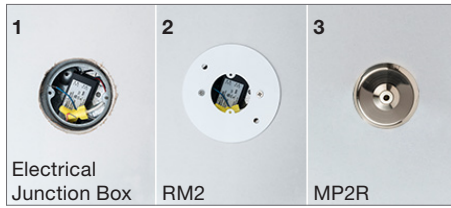

1. Existing 4SQ J-box with Round Plaster Ring
2. Add RM2 Remodel Plate with Power Supply from MP2R fixture
3. Plaster and paint ceiling, then add Canopy and fixture

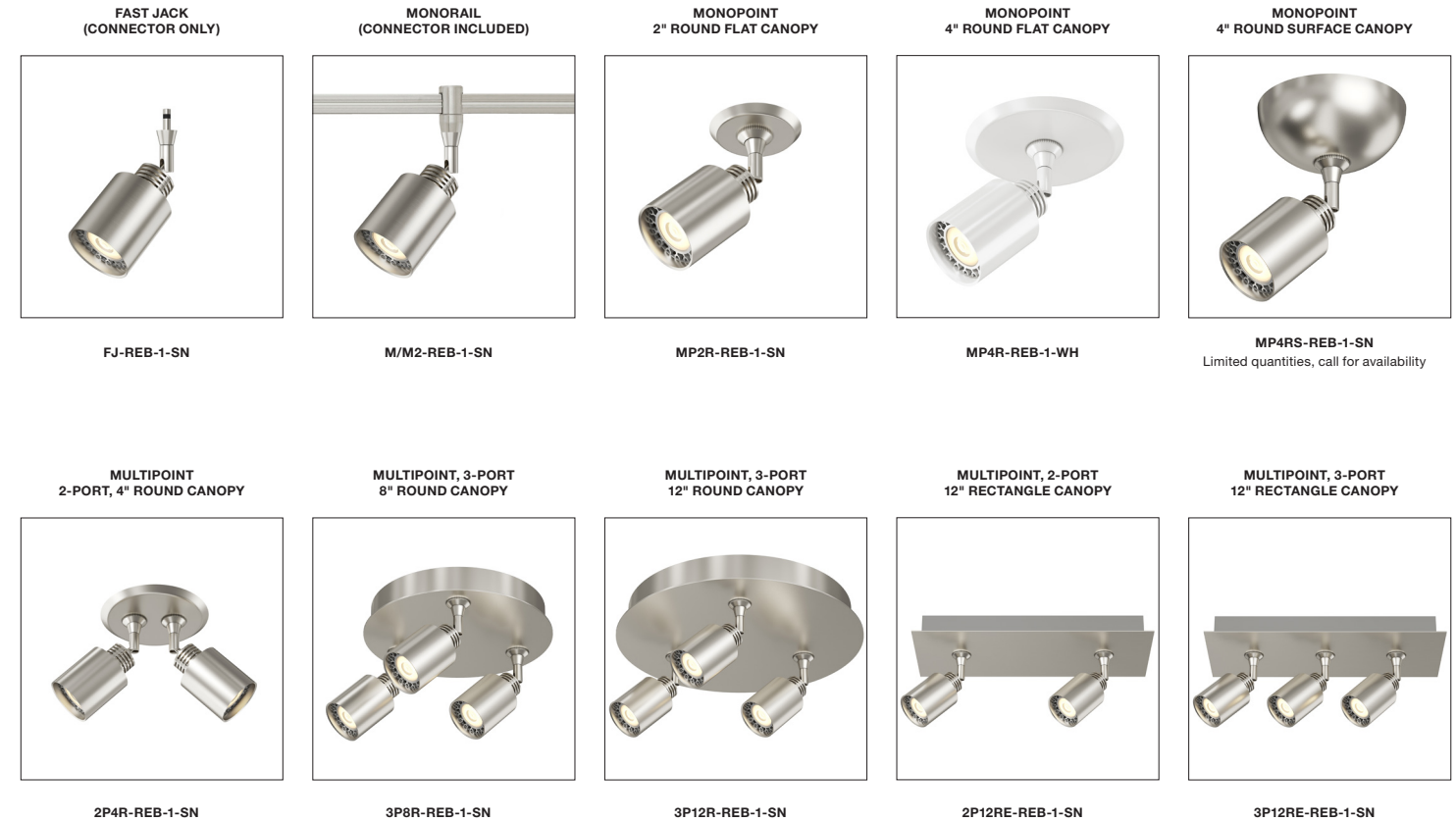

PROJECT	FIXTURE TYPE	DATE
---------	--------------	------



**Canopy Diagrams:** Canopy diagrams and measurements for Rebel LED

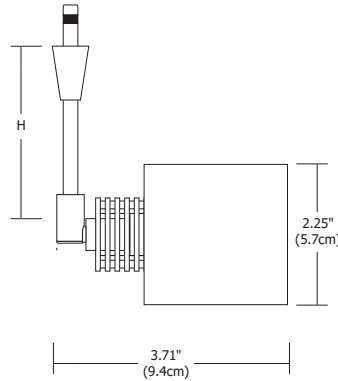

**FJ-REB**  
Removable Hot Aiming Handle  
Supplied

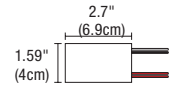

**TE-60L-12**  
60 watt 12VAC power supply included  
fits in canopy

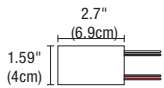

**TE-60L-12**  
60 watt 12VAC power supply included  
fits in jbox

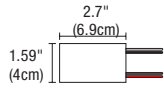

**TE-60L-12**  
60 watt 12VAC power supply included  
fits in jbox

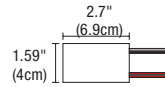

**TE-60L-12**  
60 watt 12VAC power supply included  
fits in jbox

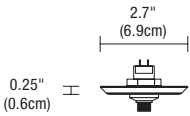
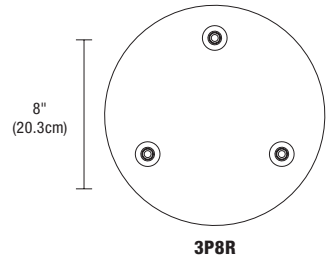
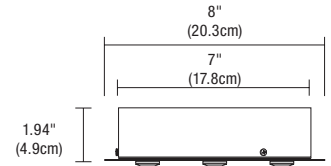

**MP2R**

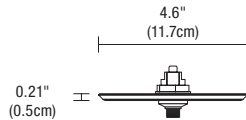

**MP4R**

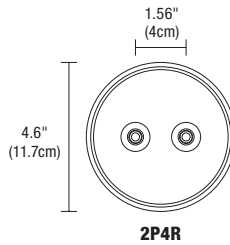
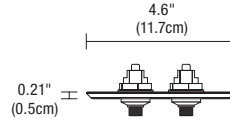

**2P4R**

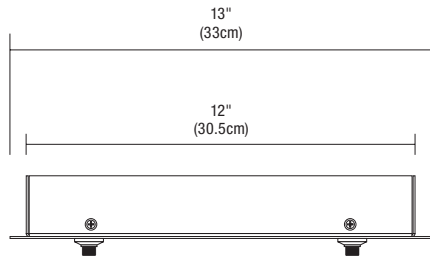
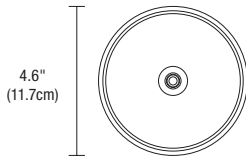

**2P12RE**

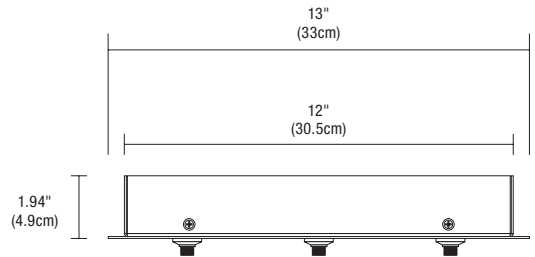

**3P12RE**

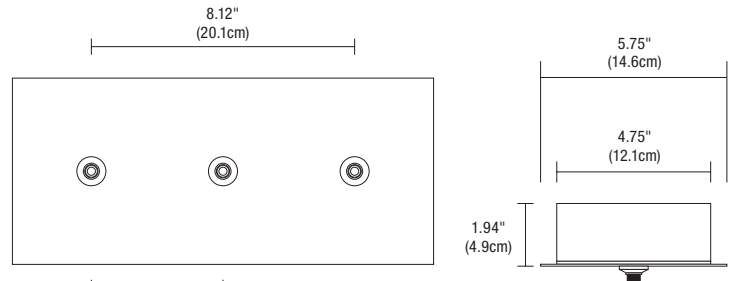
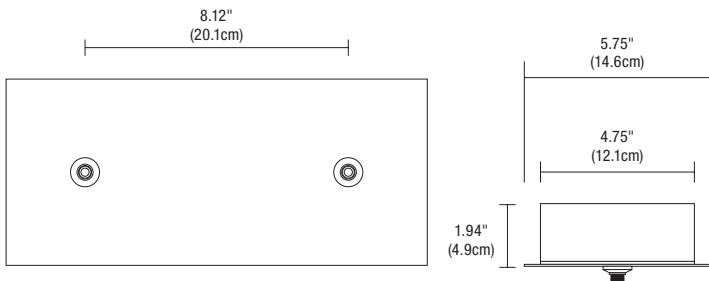

PROJECT		FIXTURE TYPE		DATE	
---------	--	--------------	--	------	--

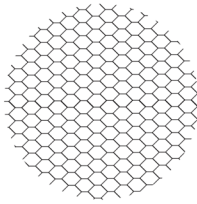

**MR16 HEXCELL LOUVER**

MR16 Hexcell Louver Accessory eliminates glare. 2" diameter x .125" thick.

Accessory

**L016-H**  
L016-H MR16 Hexcell Louver



ST16-PN



ST16-SN



STB16-BK

**SNOOT**

The Snoot prevents glare and focuses the projected light from the lamp.

Accessory

**ST16** – **SN**

ST16 Snoot MR16  
STB16 Snoot MR16

Finish

SN Satin Nickel  
PN Polished Nickel  
BK Black

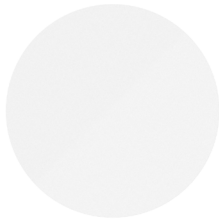

**FILM LENS SOFT FOCUS**

SF Soft Focus diffuses a beam pattern to provide even illumination. LS Linear spread lens directs 10°, 15°, 25° beams into an elongated shape. This is typically used in long rectangle paintings and art work, 35°, 40°, 60° lamps produce an elongated oval shape used in art work and wall washing.

Film Size

**LF2.0** – **SF**

LF2.0 2.0" Film

Film Type

SF Soft Focus  
LS Linear Spread

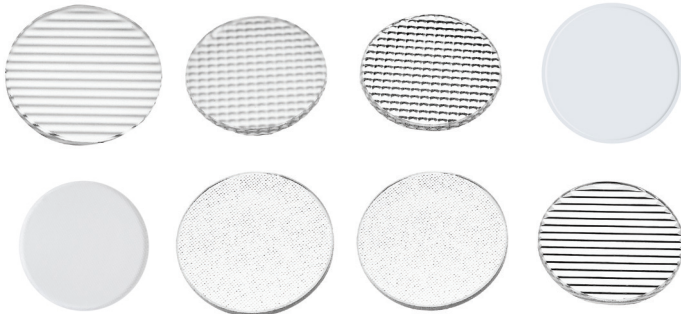

**2" ROUND GLASS OPTICAL LENS**

The soft focus lens reduces lamp glare, spread lenses elongate and diffuser lenses diffuse the light beam. UV filter lens allows quality light to pass through while blocking the ultra violet radiation.

Lens

**L16** – **SF**

L16 MR16 Lens

Optical Type

F Frost  
SF Soft Focus  
MD Medium Diffuser  
WD Wide Diffuser  
WDF Wide Diffuser Frost  
LS Linear Spread  
LSF Linear Spread Frost  
UV UV Glass

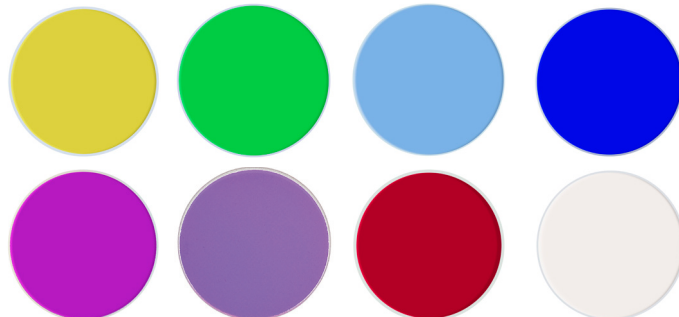

**2" ROUND DICHROIC GLASS LENS**

Dichroic lenses operate on a passive-reflective basis, reflecting unused wavelengths while allowing desired portions of the spectrum to pass through. Dichroics are high in transmission, producing brighter, cleaner, saturated colors.

Lens





**L16** – **RD**





L16 MR16 Lens

Dichroic Color

RD Red  
YL Yellow  
GR Green  
CW Cool White (3100K-4250K)  
BL Blue  
PH Peach  
DP Dark Pink  
MG Magenta

PROJECT	FIXTURE TYPE	DATE
---------	--------------	------

2700K MR16 12V LED LAMPS					
Brand	SORAA			SOL-Light	
					
Ordering Code	SMT16-07-100-927-03	SMT16-09-250-927-03	SMT16-09-360-927-03	MR16-12V-9W-NF-27KMD-SL	MR16-12V-9W-FL-27KMD-SL
Wattage	8	9	9	8	8
CRI	95	95	95	97	97
Beam Angle (Degrees)	10	25	36	24	36
Total Lumens	390	465	465	468	450
Lumens Per Watt	52	52	52	50	55
Halogen Equivalent	50	60	60	50	50

3000K MR16 12V LED LAMPS					
Brand	SORAA			SOL-Light	
					
Ordering Code	SMT16-07-100-930-03	SMT16-09-250-930-03	SMT16-09-360-930-03	MR16-12V-9W-NF-30KMD-SL	MR16-12V-9W-FL-30KMD-SL
Wattage	8	9	9	8	8
CRI	95	95	95	97	97
Beam Angle (Degrees)	10	25	36	24	36
Total Lumens	410	490	490	468	450
Lumens Per Watt	55	54	54	53	58
Halogen Equivalent	50	60	60	50	50

**SORAA VIVID MR16 36° FL**  
3000K | Rf: 90.4 | Rg: 99.5  
Color Vector Graphic

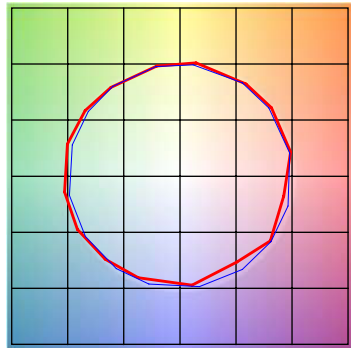

■ Test ■ Reference

GRAPHIC SHIFTS %				
HUE BIN	Rf	CHROMA	HUE	
1	94.4	1.0%	0.8%	
2	94.6	2.1%	-1.1%	
3	91.9	1.1%	-3.3%	
4	91.9	2.1%	-2.1%	
5	93.9	0.4%	-0.9%	
6	95.2	0%	1.9%	
7	93.4	2.7%	-0.7%	
8	92.7	4.2%	0.1%	
9	90.5	3.6%	-3.9%	
10	84.3	2.3%	-9.2%	
11	81.3	2.3%	-12.7%	
12	81.3	-3.6%	-10.3%	
13	90.5	-2.5%	-6.2%	
14	88.5	-8.2%	-0.4%	
15	96.2	-1.0%	0.3%	
16	86.6	-5.4%	8.2%	

**SOL-LIGHT WARM DIM MR16 36° FL**  
3000K | Rf: 94.2 | Rg: 101.2  
Color Vector Graphic

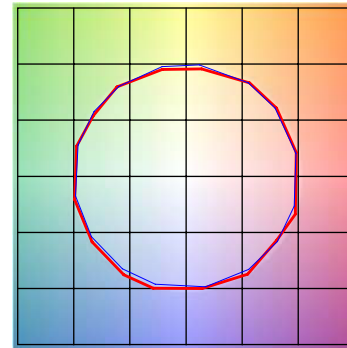

■ Test ■ Reference

GRAPHIC SHIFTS %				
HUE BIN	Rf	CHROMA	HUE	
1	96.0	0.3%	0.7%	
2	96.8	0.9%	-0.8%	
3	95.6	0.5%	-0.8%	
4	93.1	-3.2%	-2.7%	
5	95.7	-2.4%	0.4%	
6	96.8	0.4%	1.6%	
7	92.4	-1.4%	3.5%	
8	96.8	1.2%	1.2%	
9	94.0	1.4%	3.1%	
10	92.6	2.1%	3.9%	
11	92.2	3.7%	3.9%	
12	92.4	3.9%	-0.9%	
13	94.7	0.9%	-3.3%	
14	93.4	3.0%	-3.2%	
15	93.6	-1.1%	0.9%	
16	90.2	2.4%	-6.7%	

**SORAA VIVID MR16 25° NFL**  
3000K | Rf: 94.0 | Rg: 101.0  
Color Vector Graphic

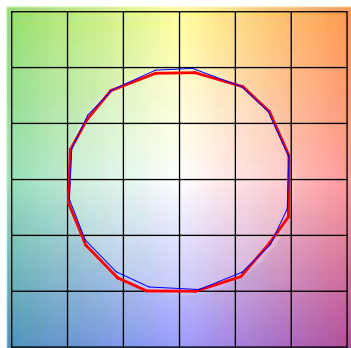

■ Test ■ Reference

GRAPHIC SHIFTS %				
HUE BIN	Rf	CHROMA	HUE	
1	95.9	0.3%	0.8%	
2	96.8	0.8%	-0.9%	
3	95.5	0.4%	-0.9%	
4	92.7	-3.4%	-2.9%	
5	95.6	-2.7%	0.4%	
6	96.8	0.1%	1.6%	
7	92.2	-1.6%	3.7%	
8	96.6	1.1%	1.5%	
9	93.7	1.4%	3.3%	
10	92.4	2.2%	4.1%	
11	92.2	3.8%	3.8%	
12	92.4	3.9%	-1.1%	
13	94.4	0.8%	-3.6%	
14	93.3	2.8%	-3.4%	
15	93.4	-1.4%	0.9%	
16	90.3	2.2%	-6.7%	

**SOL-LIGHT WARM DIM MR16 24° NFL**  
3000K | Rf: 94.2 | Rg: 101.2  
Color Vector Graphic

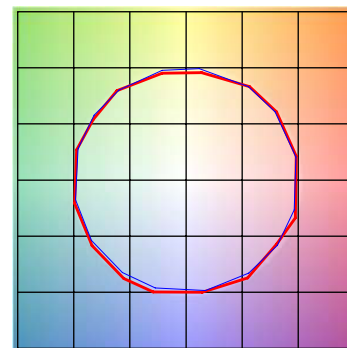

■ Test ■ Reference

GRAPHIC SHIFTS %				
HUE BIN	Rf	CHROMA	HUE	
1	95.9	0.3%	0.8%	
2	96.8	0.8%	-0.9%	
3	95.5	0.4%	-0.9%	
4	92.7	-3.4%	-2.9%	
5	95.6	-2.7%	0.4%	
6	96.8	0.1%	1.6%	
7	92.2	-1.6%	3.7%	
8	96.6	1.1%	1.5%	
9	93.7	1.4%	3.3%	
10	92.4	2.2%	4.1%	
11	92.2	3.8%	3.8%	
12	92.4	3.9%	-1.1%	
13	94.4	0.8%	-3.6%	
14	93.3	2.8%	-3.4%	
15	93.4	-1.4%	0.9%	
16	90.3	2.2%	-6.7%	

PROJECT		FIXTURE TYPE		DATE	
---------	--	--------------	--	------	--