

THE PIAZZA WALL MOUNTED FAN INSTALLATION INSTRUCTIONS

Please read and save these instructions



**These instructions are to be used in
the installation of the following
QUORUM INTERNATIONAL fans...**

The Piazza

QUORUM
INTERNATIONAL

© 2017 Quorum International. All Rights Reserved.

QUORUM'S UNIQUE LIMITED LIFETIME WARRANTY

This warranty gives you specific legal rights, and you may also have other rights which vary from state to state.

WHAT IS COVERED-

Except as specified below, the manufacturer of this product warrants it to be free of all defects in workmanship and material.

WHAT IS NOT COVERED BY THIS WARRANTY-

1. All costs of removal or reinstallation of the fan.
2. Damage resulting from failure to follow instructions contained herein.
3. Damage occurring during shipment of the product (claims must be presented to the carrier).
4. Damage resulting from accident, misuse, abuse, or neglect.
5. Damage resulting from the application of any exterior coating, or by the addition of any unapproved accessories.
6. Damage resulting from repair or attempted repair by anyone other than the manufacturer.
7. Damage resulting from causes other than product defects, including lack of

technical skill, competence, or experience of the user.

8. Light bulbs, glass or acrylic components or accessories.

9. Minor occurrences of wobble are accepted as normal and should not necessarily be considered a defect.

WHO MAY ENFORCE WARRANTY-

This warranty may be enforced only by the original purchaser. The end user must possess a dated proof of purchase from an authorized Quorum dealer to establish a warranty claim.

LENGTH OF THE WARRANTY -

1. For the fan motor - for the lifetime of the original purchaser.
2. For everything else, except blades and finish - one year from the date of purchase.
3. For fan blades and finish - 90 days from the date of purchase.

WHAT WE WILL PAY FOR -

We agree to correct defects outlined in the warranty without charge, or at our option replace the fan with an equivalent or

superior product if the defective unit is returned prepaid to us.

TO GET WARRANTY SERVICE -

To obtain warranty service, the product must be returned prepaid to Quorum. (This warranty is not enforceable outside the United States.) Details regarding return shipment are explained elsewhere in this manual. Whenever warranty service is required, ***you must present a copy of the original dated sales receipt as proof of coverage.***

There is no other express warranty. Quorum hereby disclaims any and all implied warranties, including but not limited to those of merchantability of fitness for a particular purpose to the extent permitted by law. Quorum shall not be liable for incidental, consequential, or special damages arising out of or in connection with the product use or performance except as may otherwise be accorded by law. The duration of any implied warranty which cannot be disclaimed is limited to the periods specified above in the express warranty.

WARRANTY SERVICE

1. Most problems can be handled by our customer service agents over the telephone. Customers seeking warranty repair or replacement for any fan or component are encouraged to call us for assistance. All returns must be issued a Return Goods Authorization number (RGA) prior to returning the defective unit or part. Call (817) 626-5483 - Monday thru Friday 8:00 a.m. - 5:00 p.m. CST to obtain a RGA number.
2. Arriving shipments will be refused if they do not bear a valid RGA number on the outside packaging.

3. A dated proof of purchase must accompany any fan or component clearly indicating the name of the original purchaser.

4. To avoid damage in transit, the product should be returned in its original box and packaging. Quorum will not bear responsibility for any shipping damage.

5. Any return of a fan or component must be shipped freight and insurance prepaid.

FOR YOUR RECORDS

Purchased From _____
City _____ State _____
Fan Model No. _____
Date Purchased _____

Complete and mail the enclosed warranty card within 10 days to ensure your warranty is registered.

If you have any questions regarding the warranty, or the procedures for obtaining service, please call us at (817) 626-5483 - Monday thru Friday 8:00 a.m. - 5:00 p.m. CST.

1. SAFETY RULES

Model #94144-xx: 32.84 lbs

1. To avoid possible electric shock, turn off the electricity at the main fuse box or circuit panel before you begin the fan installation or before servicing the fan or installing accessories.

2. Read all instructions and safety information carefully before installing your fan and save these instructions.

3. Make sure all electrical connections comply with local codes or ordinances as well as the National Electrical Code. If you are unfamiliar with electric wiring, please use a qualified and licensed electrician.

4. When cutting or drilling into wall or ceiling, do not damage electrical wiring and other hidden utilities.

5. Before applying power, visually re-inspect the installation. Make sure that all guards and protective devices are securely in place and all visible screws and bolts are tightened. All set-screws must be retightened before installation.

6. The wall outlet box must be securely mounted, and **capable of supporting at least 50 pounds**. To reduce the risk of fire, electric shock, or personal injury, use only an outlet box clearly labeled "**Acceptable For Fan Support**".

7. To reduce the risk of personal injury, do not bend blades or any other part of fan when cleaning. Do not insert foreign objects in between rotating fan blades or in pace surrounding entire rotating fan unit. Fan must be turned off at power at supply source before installation, cleaning or servicing.

8. To reduce the risk of personal injury, install the supplementary mounting means and use only the hardware provided with the fan.

9. After installation is complete, check that all connections are absolutely secure.

10. Do not attempt to control the operation of the fan from any wall control that is not approved by Quorum for use with its fans. Do not use solid state wall controls. The use of any unapproved control voids the fan's warranty.

TOOLS REQUIRED FOR INSTALLATION

Phillips Screwdriver
Wire Cutters
Electrical Tape
Step Ladder

2. UNPACKING YOUR FAN

Unpack your fan and check the contents. Do not discard the carton. If warranty replacement or repair is ever necessary the fan should be returned in original packaging. Remove all parts and hardware. Do not lay motor housing on its side - because the decorative casing may shift. Check all visible screws, bolts and nuts for tightness. Examine all parts. The following parts should be included:

1. Fan motor assembly (a)
2. Wall mounting plate screws (b) (pre-installed on fan base)
3. Bundled wires and 4 wire nuts (c)
4. Wall switch, 2 mounting screws and 3 wire nuts, wall plate w/2 mounting screws and 2 machine screws (d)

NOTE:

Some Quorum fan models will have slightly different parts than what is shown here depending upon the design you have chosen. Basic installation procedures are similar for all models.

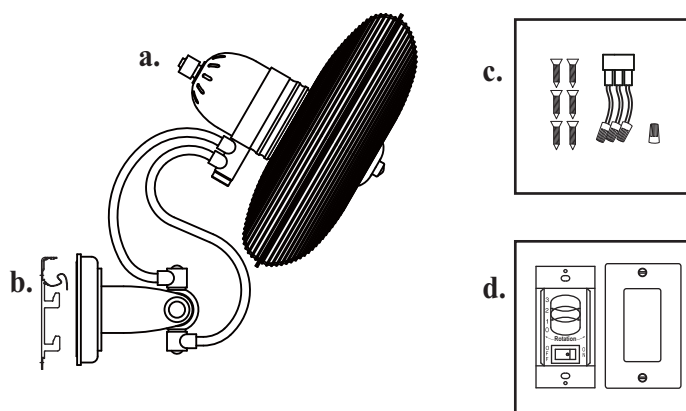

IF YOU FIND THAT PARTS ARE MISSING, CONTACT YOUR DEALER FOR REPLACEMENT, OR CALL QUORUM DIRECTLY AND WE WILL MAIL REPLACEMENTS TO YOU IMMEDIATELY.

3. MOUNTING OPTIONS

1. Disconnect the power by removing fuses or turning off circuit breakers.

2. If there is an existing wall junction box, ensure it is clearly marked “Suitable for Fan Support”. If it is not so marked, it must be replaced with an approved one.

3. Secure the wall junction box (or make sure the existing box is secured) directly to the building structure. Use appropriate fasteners and building materials.

CAUTION: TO REDUCE THE RISK OF PERSONAL INJURY, INSTALL THE PRIMARY MOUNTING MEANS AND USE ONLY THE HARDWARE PROVIDED WITH THE FAN.

WARNING: TO REDUCE THE RISK OF ELECTRIC SHOCK, FIRE, OR PERSONAL INJURY, MOUNT THE FAN ONLY TO AN OUTLET MARKED ACCEPTABLE FOR FAN SUPPORT.

Fig. 1

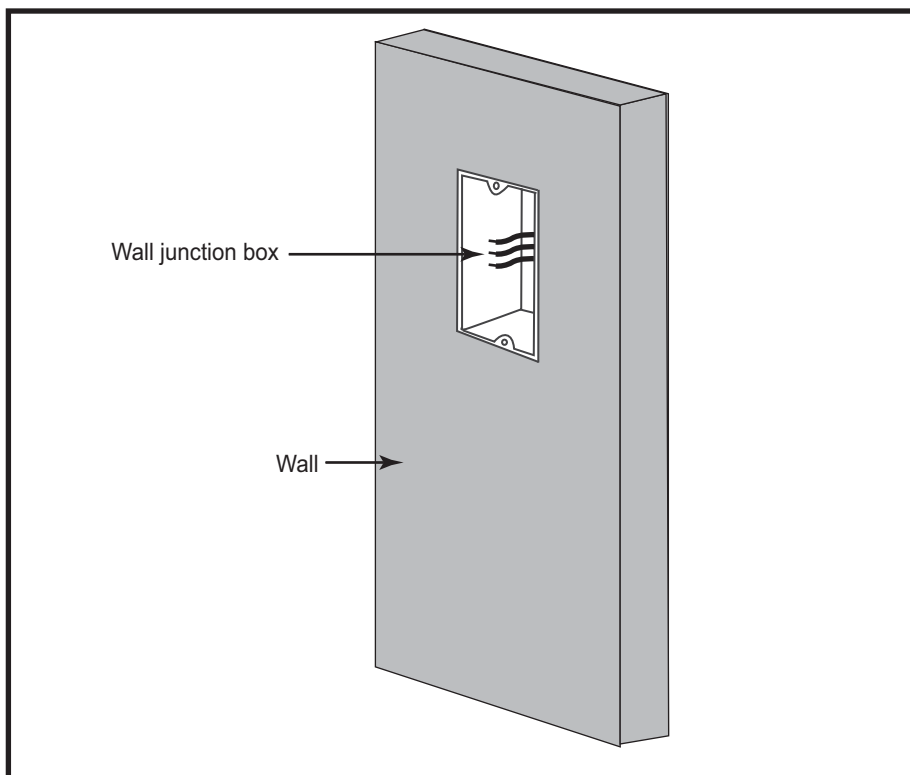

4. MOUNTING/INSTALLATION OF THE FAN

WARNING – Turn off the power.

1. Remove the wall mounting plate from the fan base by removing the one fan base screw on the top fan base, keep it for future use.

2. Install the wall mounting plate to the wall junction box and secure with six screws provided. (Figure 2)

3. Remove the three wire nuts from the bundled wires. (Figure 3)

4. Attached the bundled wires to the building supply wires out of the wall junction box with wire nuts removed previously. (Figure 3)

- Black to black
- White to white
- Blue to blue

5. Hanging the fan motor assembly to the wall mounting plate, ensure the two hanging bars sliding into the notch of hook completely. (Figure 4)

NOTE: Make sure the two wire connectors are revealed through the wireway passage after hanging the fan motor assembly onto the wall mounting plate.

6. Detach the wireway passage plate from the fan base by removing two screws from the fan base. (Figure 5) The plate covers a temporary wireway passage for making the wiring connection.

7. Make the connection for the two wire connectors, and then tuck the wires inside the fan base. (Figure 5)

If your wall junction box has a ground wire (green or bare copper), connect the wall mounting plate's yellow/green ground wire to it; otherwise connect the wall mounting plate's yellow/green ground wire directly to one of the screws from the wall mounting plate.

8. Re-attach the wireway passage plate onto the fan base and secure with screws removed previously. (Figure 6)

9. Re-install the fan base screw that removed previously into the fan base. (Figure 6)

10. Your wall fan is now completed the wall mounted installation.

Fig. 2

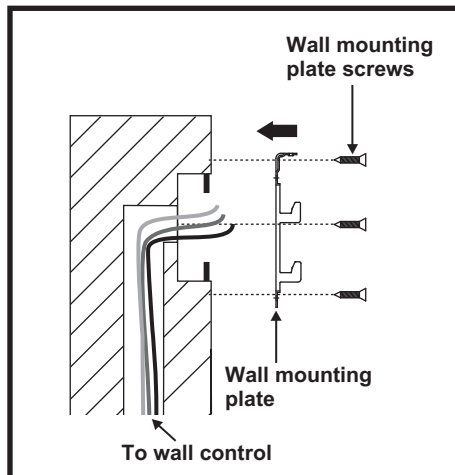

Fig. 3

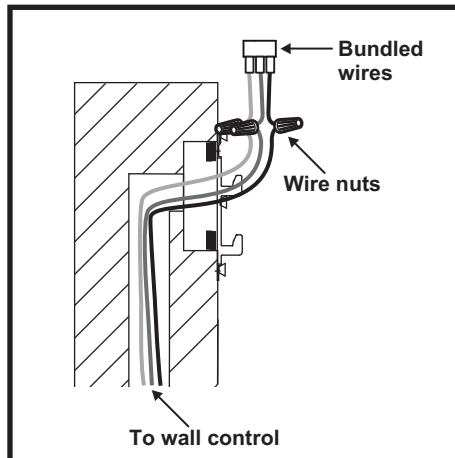

Fig. 4

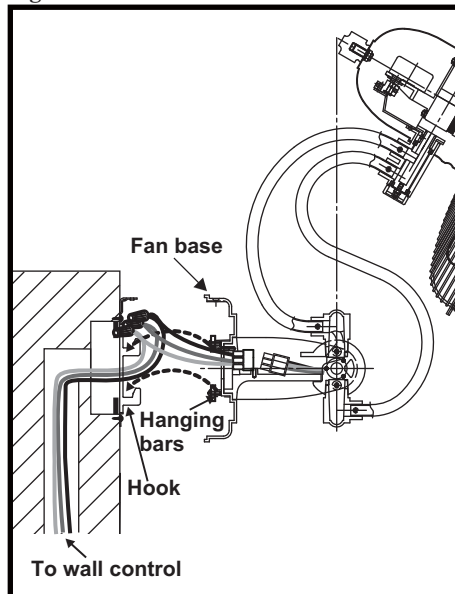

Fig. 5

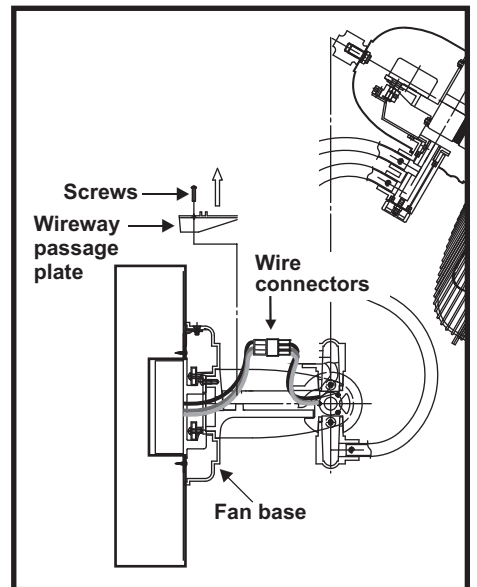
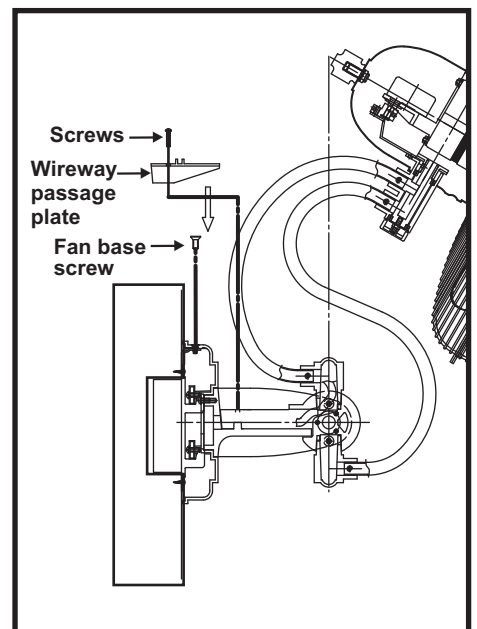

Fig. 6



5. ELECTRICAL CONNECTIONS

REMEMBER -Turn off the power!

Use the wire nuts supplied with your fan when making connections. Secure the connectors with electrical tape and make sure there are no loose connections or wire strands.

Connect the wiring from the wall switch receptacle to the wall control unit.

- Remove the existing wall plate and switch from the wall junction box.
- Connect blue wire (labeled “FOR OSCILLATION”) from wall control to blue or red wire from wall junction box,
- Connect black wire (labeled “TO MOTOR L”) from wall control to black wire from wall junction box.

- Connect the black/white wire (labeled “AC IN L”) from the wall control to the black wire from A/C supply source.

- If your wall junction box has a ground wire (green or bare copper), connect the wall control wall mounting plate’s yellow/green ground wire to it; otherwise connect the wall control wall mounting plate’s yellow/green ground wire directly to one of the screws from the wall junction box.

- Carefully tuck the connected wires inside the junction box. Secure the wall control with the two screws provided. Attach the face plate over the wall control with the two screws provided.

Use **ONLY** wall controls approved by Quorum. Use of unapproved wall controls will cause unacceptable humming noise, and avoids the fan warranty.

Hook up in "series only" do **not** connect the hot and neutral wires of electric circuit to the wall control - damage to the wall control and possible fire could occur.

NOTE: The wire connection for this fan requires that a three-conductor cable with ground wire be run between ceiling and wall junction box, or the oscillating feature will not work.

Fig. 7

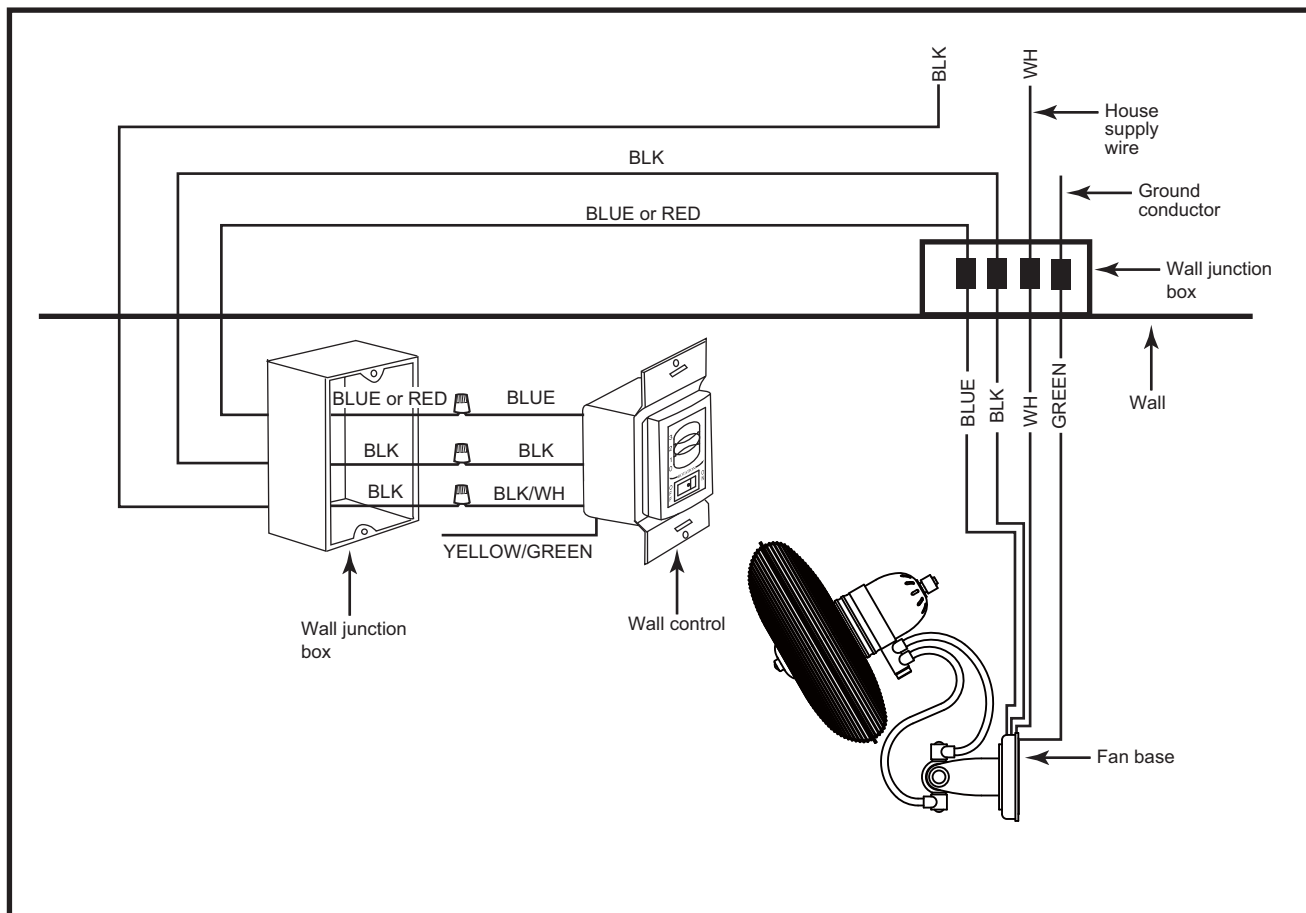

6. FAN OPERATION AND CARE

Restore power to the ceiling fan and test for proper operation.

A. The fan 3-speed control knob is used to control the fan blade speed as follows:

0= Turns the fan off

1= High Speed

2 = Medium Speed

3= Low Speed

“OFF-ON” Button:

This button is used for oscillating operation. Press “ON” to set the fan to a 45 degree oscillation. Press ‘OFF” to turn off the oscillation. The fan will stay at the same direction where the oscillation is turned off.

1. A wall fan is an environmentally smart choice to cool your home or office. Adjust your HVAC thermostat during fan use to save additional energy and money on your air conditioning utility bills. You should see a significant reduction in your cooling costs by regular use of your fan.

2. A clicking or a rattling noise is a sure indication of loosening screws. Since screws will invariably work loose over time, at least once a year, tighten all the screws for this fan.

3. Clean you fan periodically using only a cloth dampened with a mild detergent solution for all hardware - never use solvents. The finish plating is lacquered to prevent tarnishing. Use a lint-free cloth with clean water to clean blades.

4. You will never need to oil or lubricate your fan. Its permanently sealed bearings will provide trouble free, silent operation for many years.

5. If repairs or servicing are ever required, to avoid possible electric shock, **turn off the electricity** at the main fuse or circuit panel before you begin.

Fig. 8

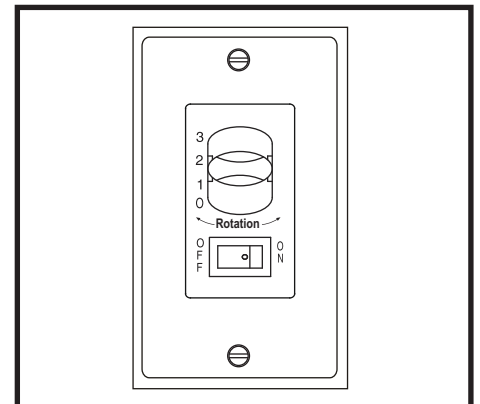

7. TROUBLESHOOTING

FAN WILL NOT START

1. Check that the electricity has been turned on at the circuit breaker which had probably been turned off during installation.
2. Turn off the electricity. Check all connections in the wiring of the fan at the wall and make sure it follows the wiring instructions outlined in this manual.

NOISE

Note: Always allow a day or two "run-in" time for any new fan at medium or high speed. When attempting to diagnose noise, listen carefully from several sides to try and isolate the location of the noise (fan base, blade, fan cage, motor, etc.)

1. Check to see that all screws are tight in the fan cage connection to the motor face plate.
2. Turn off the power. Loosen the fan base and check that the wiring and/or wire nut connectors are not resting against the fan base, possibly vibrating while the fan is on.

3. Use of a standard light rheostat or an unapproved fan wall control to control the fan speed will always cause an annoying "hum". Many fan motors do not work quietly with solid state variable speed controls.

REPLACEMENT PARTS AVAILABLE

A full range of genuine replacement spare parts are available at reasonable cost directly from Quorum International. Please call us at (817) 626-5483. Monday through Friday from 8:00 A.M. to 5:00 P.M. CST.