

## BRAQUE TABLE

Installation Guide

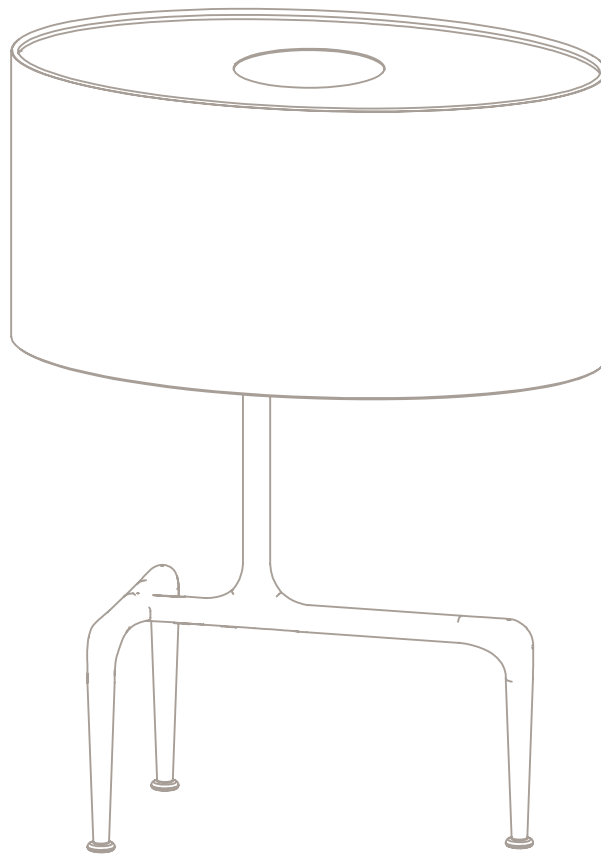

!

Please handle with care and wear gloves at all times during assembly and installation to avoid damaging components.

## TECHNICAL

**Bulb Holder**  
240v - 1 x E27  
120v - 1 x E26  
(bulbs not supplied)

**Wattage**  
60w max (or 8w LED 2700k)

**Weight**  
2kg (4.4lbs)

## PARTS & COMPONENTS

A. 1 x Braque table base  
B. 1 x Shade

A.

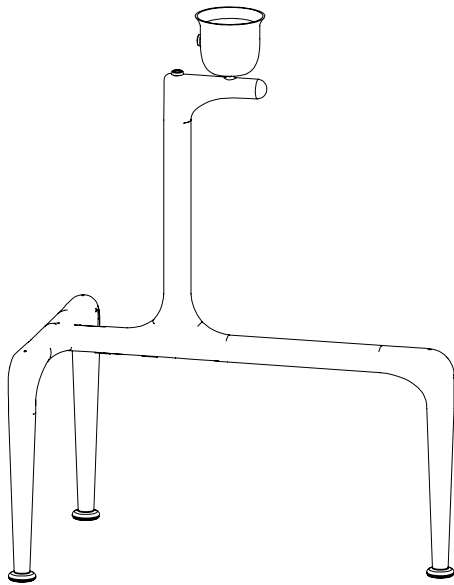

B.

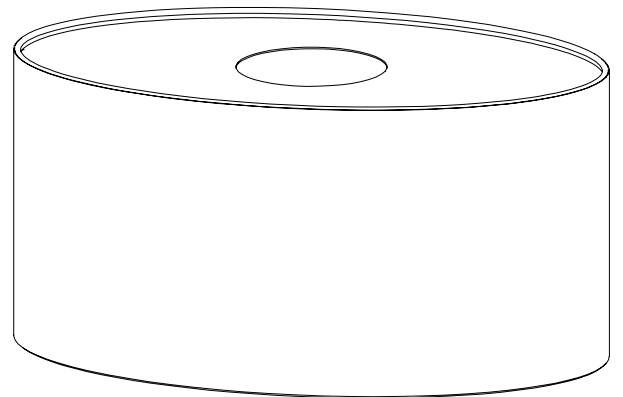

- All nuts and bolts required for the installation will be included in the delivery.



## **BEFORE INSTALLATION**

- Check that you have all components before starting assembly.
- Assembly must be carried out by a qualified electrician.

1. Fix the fabric shade to the body by placing on the lamp holder and screwing with the supplied shade ring.

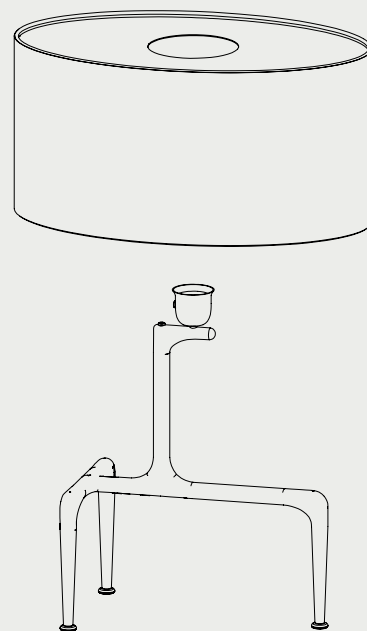

2. Fit the bulb (not supplied) to the lamp-holder.

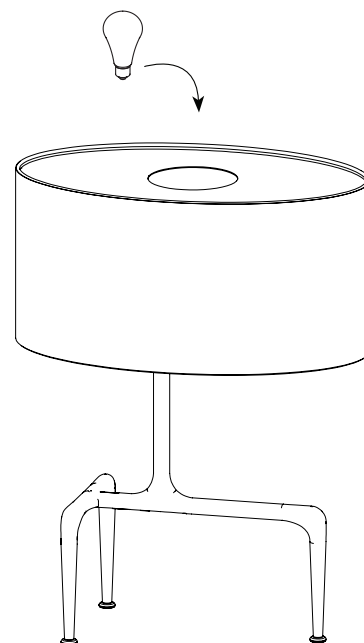

## MAINTENANCE

### Cleaning

Dust using a dry lint-free cloth weekly or as required

### Repairs

Contact  
CTO Lighting

### Warranty

Please visit  
[www.ctolighting.co.uk/  
pages/f-a-q](http://www.ctolighting.co.uk/pages/f-a-q)  
for CTO warranty policy

### Certification

