

HERON FLOOR

Installation Guide

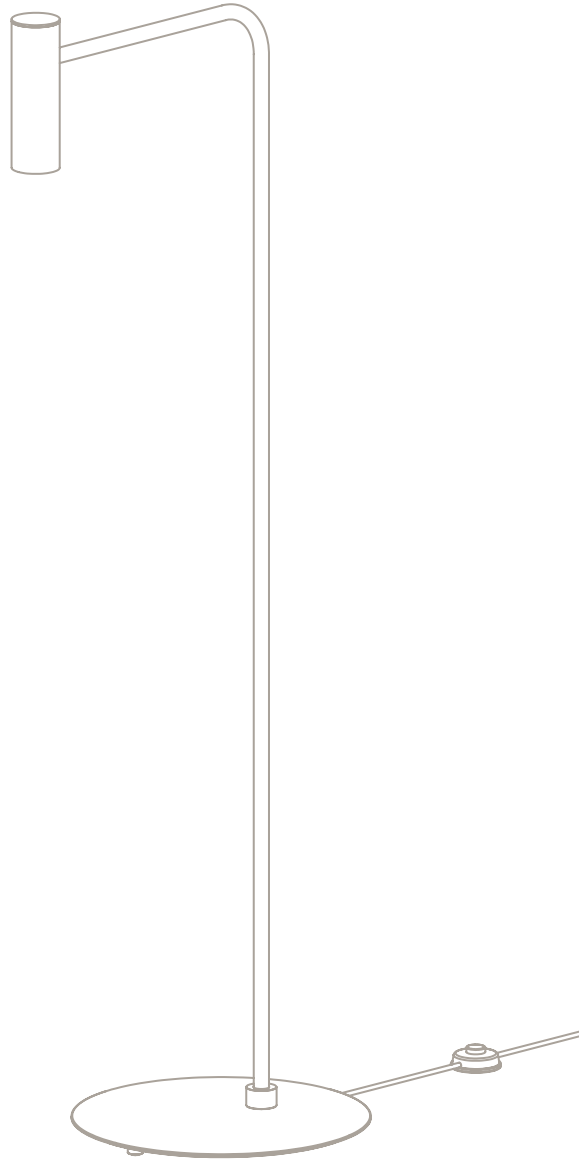

!

Please handle with care and wear gloves at all times during assembly and installation to avoid damaging components.

TECHNICAL

Bulb Holder
 240v - 1 x GU10
 120v - 1 x GU10
 (bulbs not supplied)

Wattage
 5.5w - 2700k - LED ONLY

Weight
 brass base 9kg (19.8lbs)
 marble base 13kg (28.7lbs)

PARTS & COMPONENTS

A. 1 x Heron stem, 1 x Heron base, 1 x In-line switch and cord set

B. 4 x M5 screws

C. 1 x Cable clamp and screws

1 x Bulb removal tool

A.

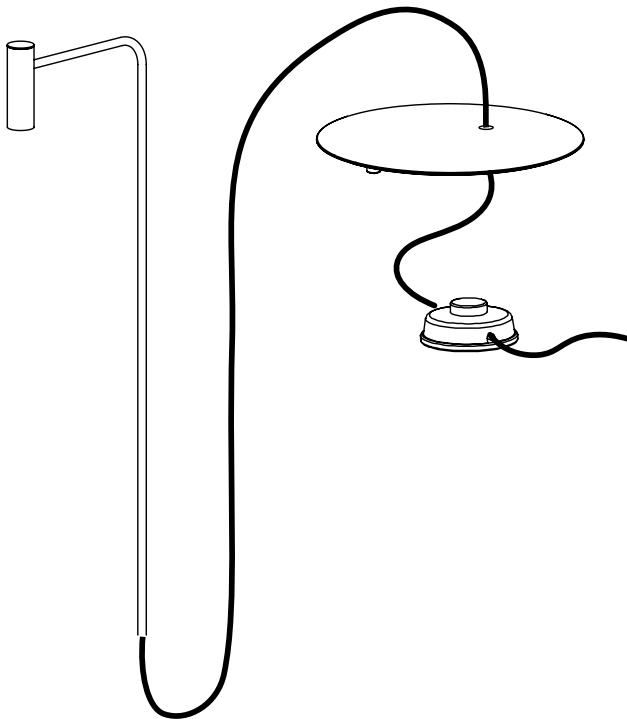

B.



C.

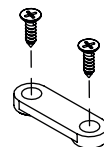

- All nuts and bolts required for the installation will be included in the delivery.



BEFORE INSTALLATION

- Check that you have all components before starting assembly.
- Assembly must be carried out by a qualified electrician.
- You will need the below specific tools for a successful assemble.

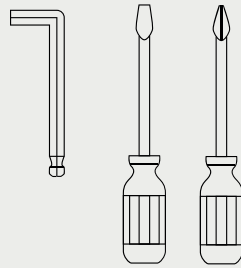

1. Remove the top layer of polystyrene packaging and place them on top of the lid creating a soft resting surface.

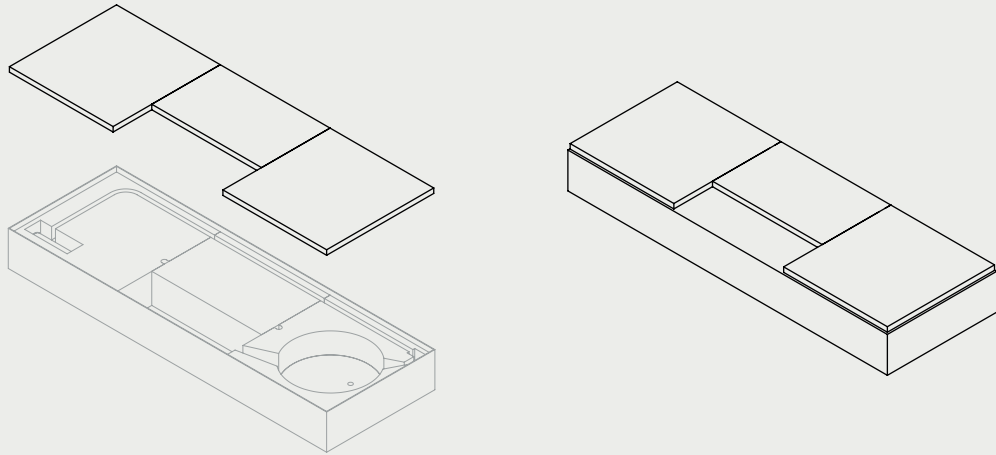

2. Carefully remove the Heron Stem and Base from the box and place on top of the box lid.

Note: Do not remove any of the protective nylon sleeves from the light until the assembly is complete.

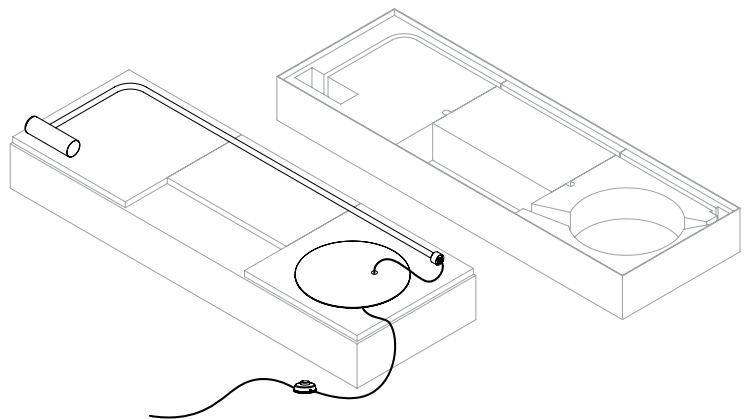

3. Remove the two large polystyrene sections from the box and place them upright, with the grooves in line with each other, creating a platform for the Heron stem.

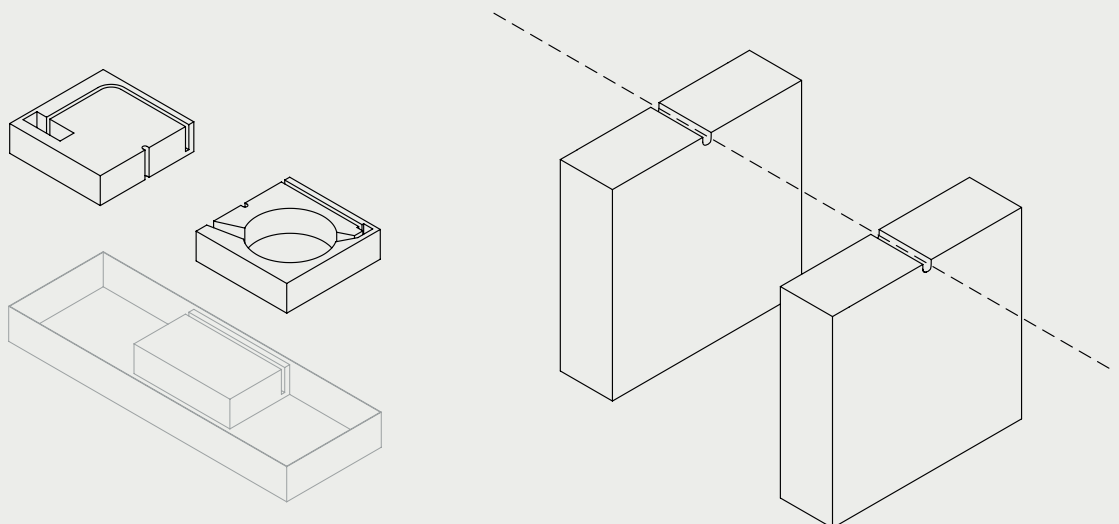

4. Note: Support the Heron Stem and Base at all times during assembly.

Place the Heron stem on the polystyrene sections and lift the Heron Base into place.

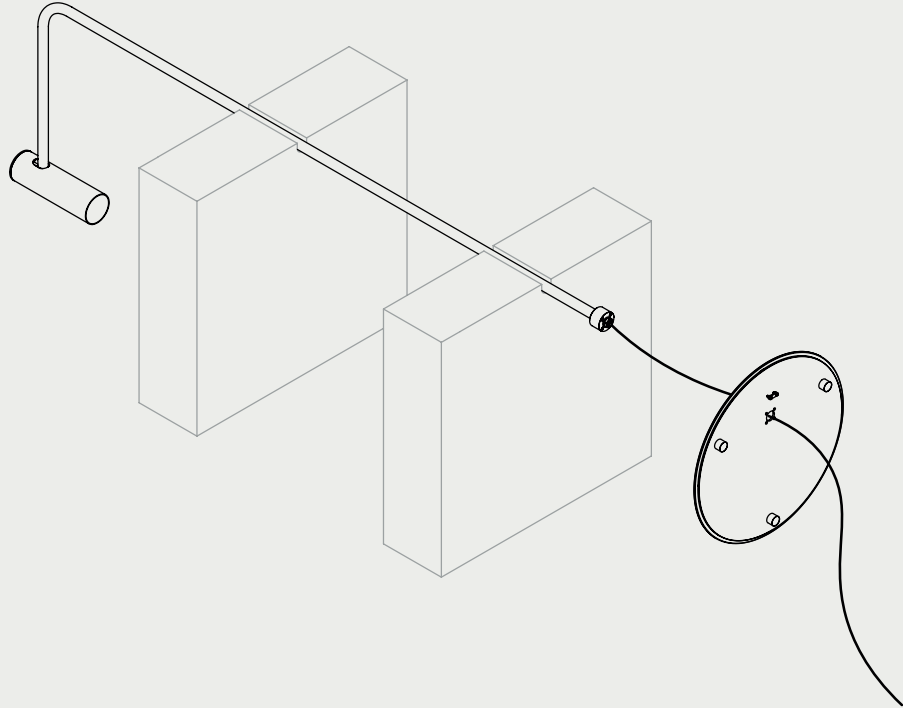

5. With the base positioned on the end of the stem in the correct orientation, secure with the 4 x screws.

Note: Ensure that all four screws are fully tightened.

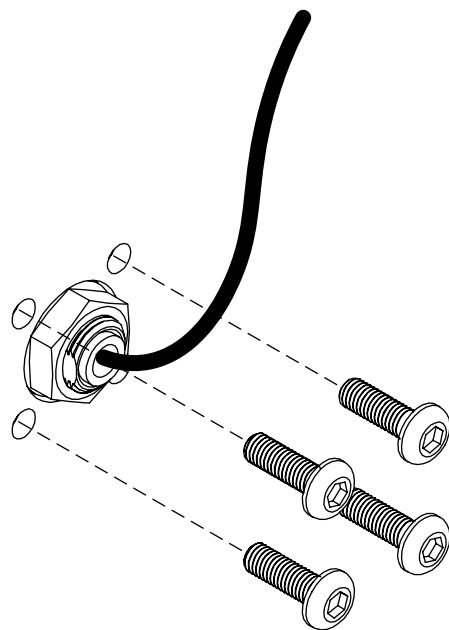

6. With the base securely fixed to the bottom of the stem, clamp the cable to the base using the supplied clamp and screws.

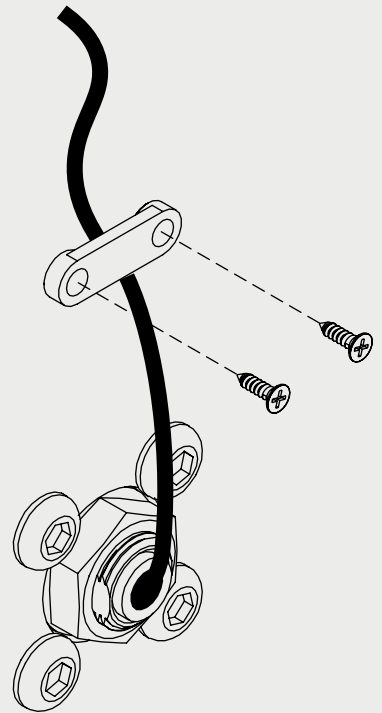
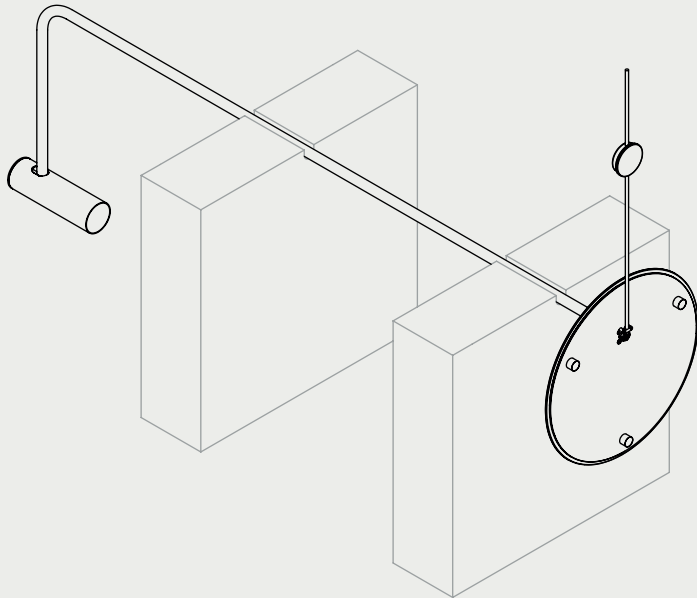

7. Lift the Heron Floor upright, supporting the base and stem at all times.

Fit the Heron Floor with a 5w LED GU10 using the supplied bulb removal tool.

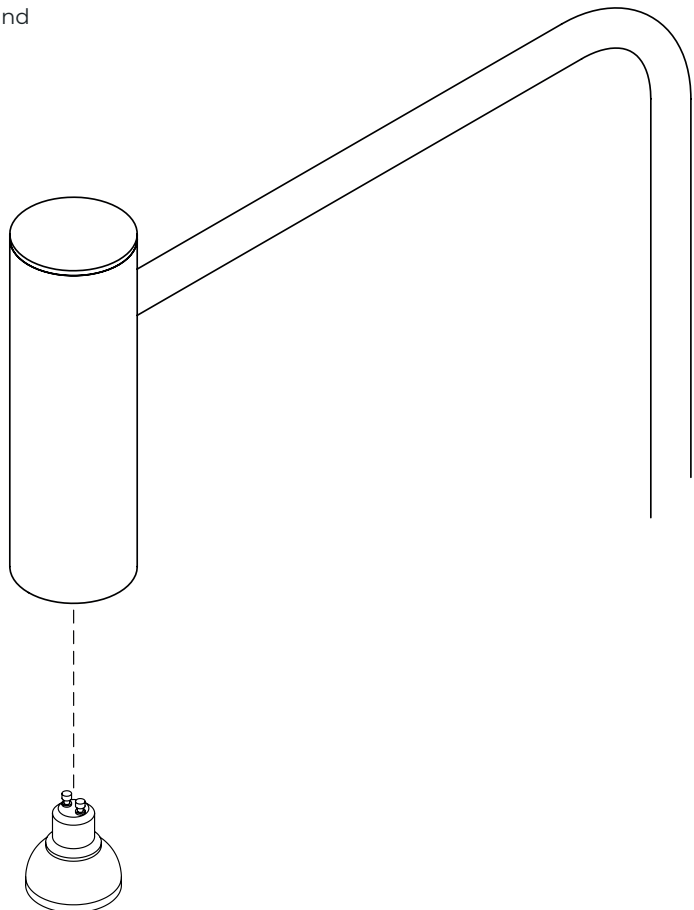

MAINTENANCE

Cleaning

Dust using a dry lint-free cloth weekly or as required

Repairs

Contact
CTO Lighting

Warranty

Please visit
[www.ctolighting.co.uk/
pages/f-a-q](http://www.ctolighting.co.uk/pages/f-a-q)
for CTO warranty policy

Certification



E492309