

NIMBUS ROUND MEDIUM PENDANT

Installation Guide

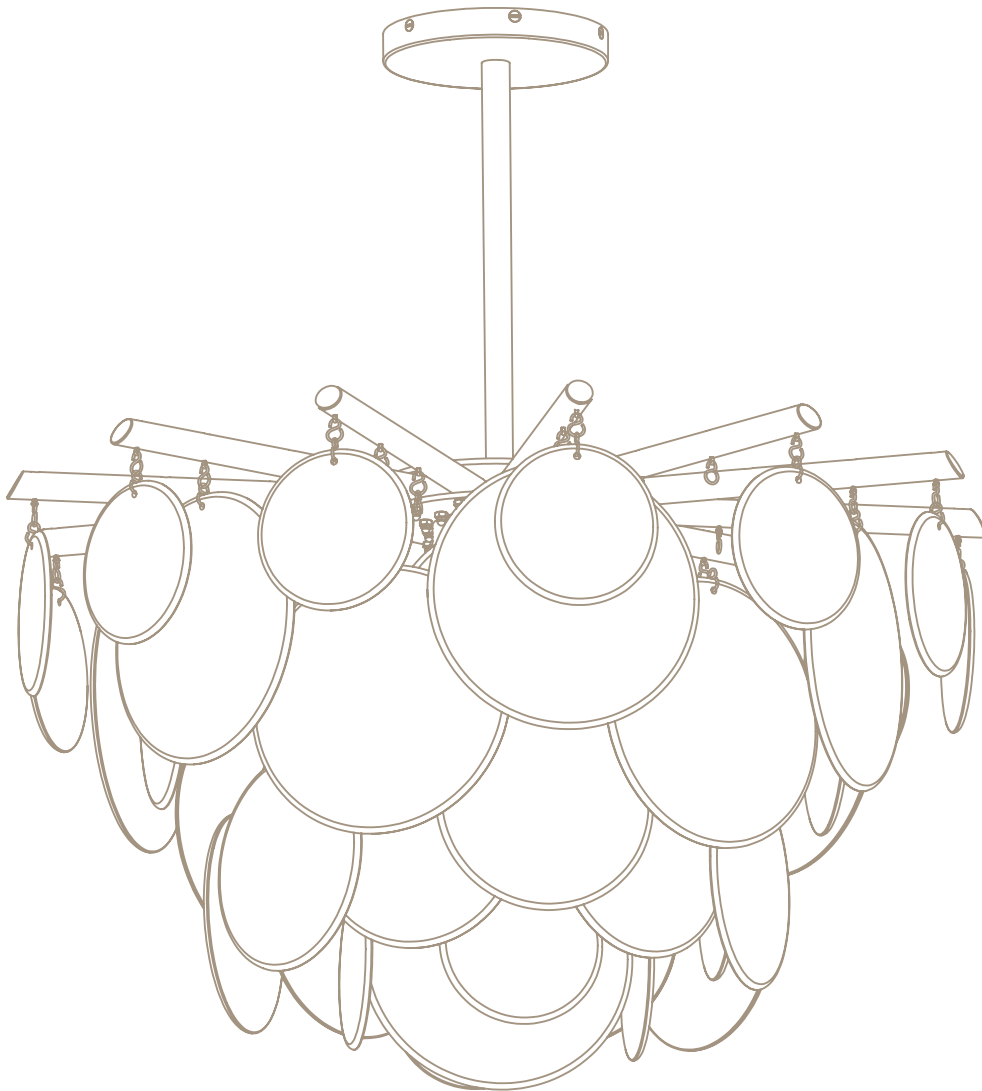

!

Please handle with care and wear gloves at all times during assembly and installation to avoid damaging components.

TECHNICAL

Bulb Holder
 240v - 4 x E14
 120v - 4 x E12
 (no bulbs supplied)

Wattage
 60w max halogen
 (or 6.5w LED 2700k)

Weight
 38kg (83.8lbs)

PARTS & COMPONENTS

A. 1 x Nimbus round medium cross member
 B. 1 x Ceiling rose and drop rod
 C. 1 x Mounting plate
 D. 1 x Lamp holder assembly
 E. 1 x Bottom glass disc, 1 x Central glass drop
 (Chain 25mm)

F. 44 x Glass discs

2 x A1 (150mm OD)
 2 x A2 (250mm OD)
 2 x A3 (200mm OD)
 2 x A4 (250mm OD+150mm OD)
 4 x B1 (150mm OD)
 4 x B2 (250mm OD)
 4 x B3 (200mm OD)

4 x C1 (150mm OD)
 4 x C2 (250mm OD)
 4 x C3 (200mm OD)
 2 x D1 (150mm OD)
 2 x D2 (250mm OD)
 2 x D3 (200mm OD)
 2 x D3 (250mm OD + 150mm OD)

A.

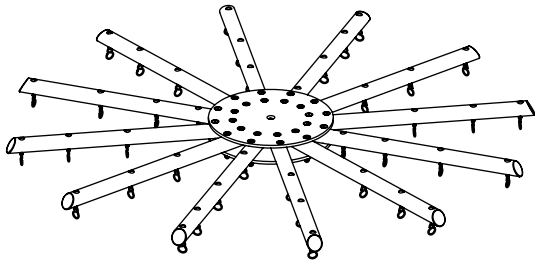

B.

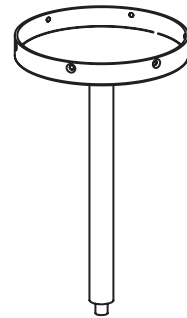

C.

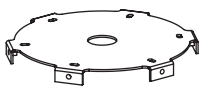

D.

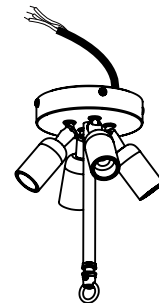

E.

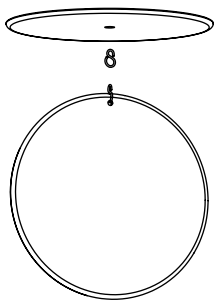

F.

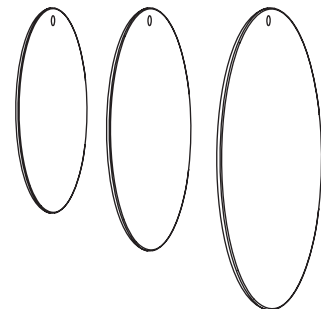

- All nuts and bolts required for the installation will be included in the delivery.
- All glass discs will be supplied labelled and ready to be mounted on to the cross member (hooks and chain attached).
- Few spare hooks are supplied, use them only in the occasion of some missing from the glass discs.



BEFORE INSTALLATION

- Check that you have all components before starting the installation.
 - Installation must be carried out by a qualified electrician.
 - A minimum of two people is required to install a pendant light.
- Check that the ceiling or wall fixings are suitable and strong enough to support the weight of the light fixture.
 - You will need the below specific tools for a successful installation..

If height adjustment on site is required please see height adjustment instructions on page 4, before you start assembling the pendant.

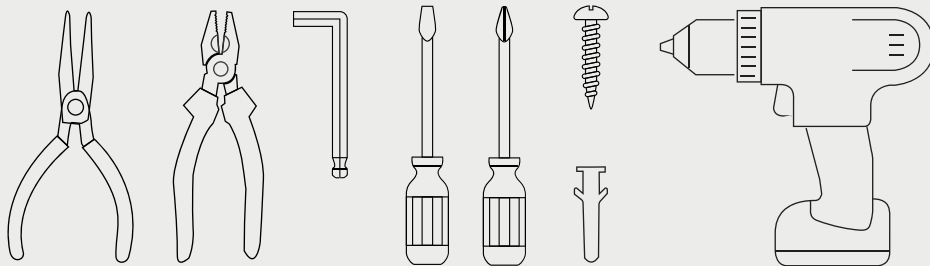

HEIGHT ADJUSTMENT INSTRUCTIONS

Before attaching the drop-rod to the body of the light, calculate the required total drop from ceiling to bottom of pendant. If any height adjustment is required, follow the steps below:

1. Separate the brass tube and the internal threaded tube from the ceiling rose cover by unscrewing the bolt.
2. Measure the length the drop rod needs to be.
3. Cut the brass tube to this length using a hacksaw or similar tool.
4. Cut the same length from the internal threaded tube using a hacksaw or similar tool.

NOTE: You must allow 25mm extra internal threaded tube at each end of the brass tube so that it can be bolted into place with the nuts provided.

5. Once the brass tube and internal threaded tube are cut to the correct lengths, assemble them back together by using all components provided and mount the internal threaded tube to the ceiling rose cover using the bolt.

Ensure that the bolts are tightened and fully secure.

8. Slide the brass tube over the internal threaded tube and attach the top plate of cross-member with bolt, as shown.
9. Once satisfied with the fit secure bolts and all-thread with Loc-tite or similar adhesive.

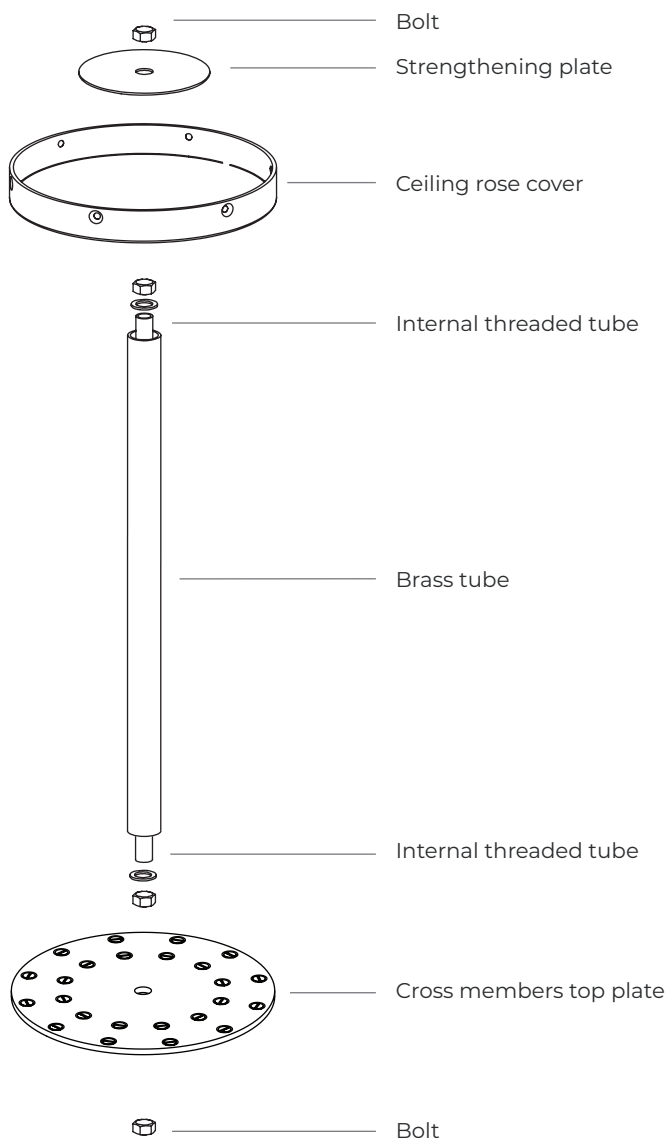

1. Remove the first M13 nut from the bottom of the drop rod (leave the second nut) and attach the drop rod to the top plate of the cross member, replacing the nut and tightly securing (socket set required).

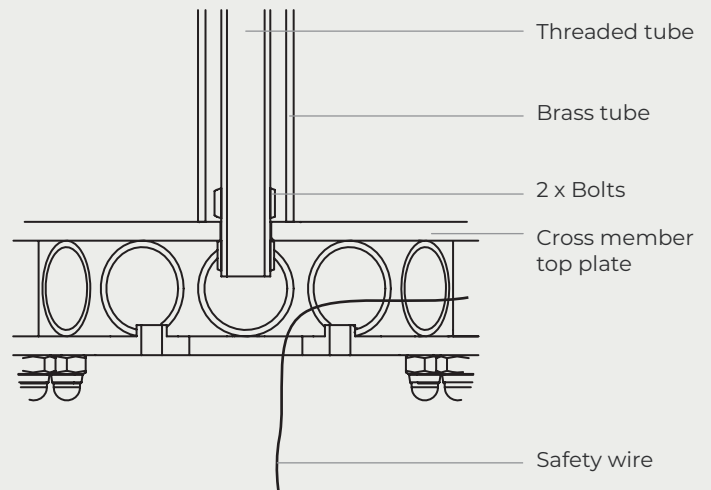

2. Insert the safety wire (already attached to the cross-member) through the drop-rod and ceiling rose.

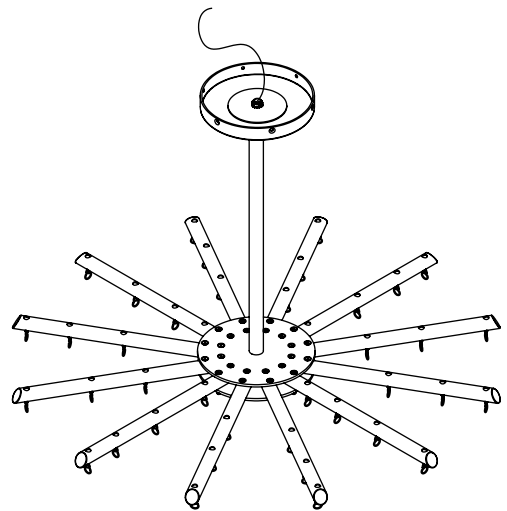

3. Remove the steel plate from the lampholder assembly by removing the 4no. machine screws located on the sides and attach the plate to the cross member bottom plate using the 2no. supplied machine screws.

Fit the cable from the lampholder assembly through the cross member and up the drop rod, pulling the excess cable through the top.

Place the lampholder assembly over the plate, pulling through any excess cable through the top and use the 4no. screws to secure it in place.

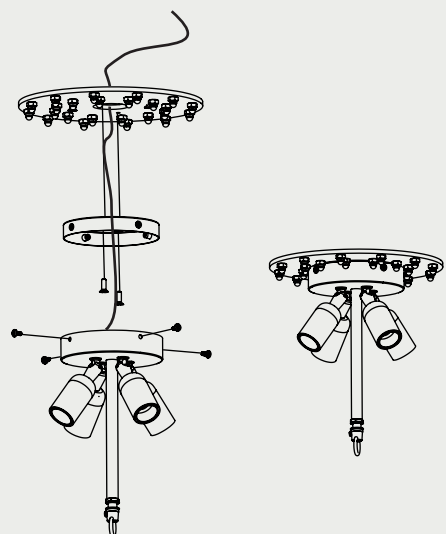

4. Fix the mounting plate to the ceiling.

Ensure that suitable screws are being used for the surface you are mounting to (not supplied).

Attach the safety wire onto a strong and stable point on the ceiling to secure the pendant (strong enough to support 100kg).

Raise the pendant and make the electrical connections within ceiling rose, ensuring all wires are colour matched and the pendant is earthed correctly.

Bring the ceiling rose up to the mounted plate and secure using provided screws.

Note: Ensure that the weight of the pendant is fully supported during the electrical installation.

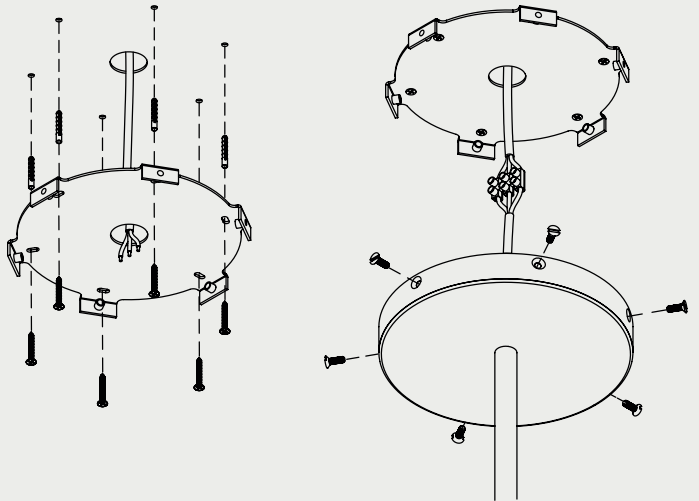

4. 120V

US Fix the mounting plate over the junctionbox.

Ensure that suitable screws are being used for the surface you are mounting to (not supplied).

Attach the safety wire onto a strong and stable point on the ceiling to secure the pendant (strong enough to support 100kg).

Raise the pendant and make the electrical connections inside the junction box ensuring all wires are colour matched and the pendant is earthed correctly.

Bring the ceiling rose up to the mounted plate and secure using provided screws.

Note: Ensure that the weight of the pendant is fully supported during the electrical installation.

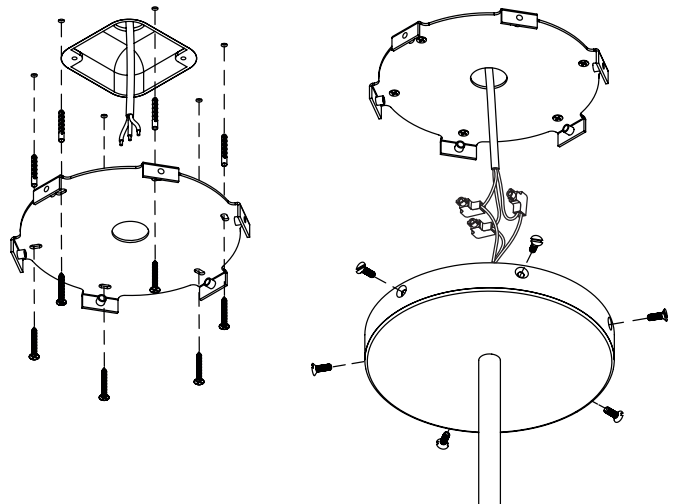

5. With the pendant securely attached to the ceiling, fit the 4 bulbs to the lampholders.

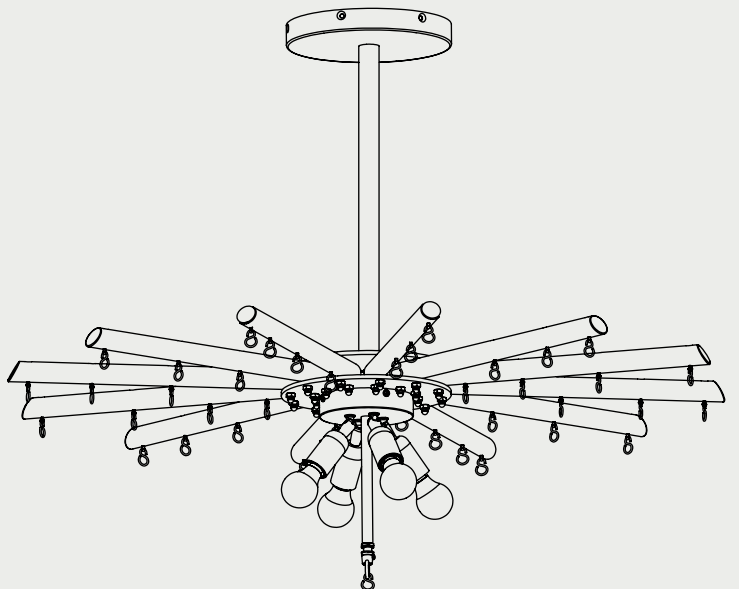

6. Fit the bottom glass disc to the lampholder assembly by removing and replacing the threaded ring and rubber washers each side of the glass (as shown in diagram).

Do not over tighten the threaded ring as it may cause the glass disc to crack.

Tighten the small M3 screw located on the side of the threaded ring to secure it in place.

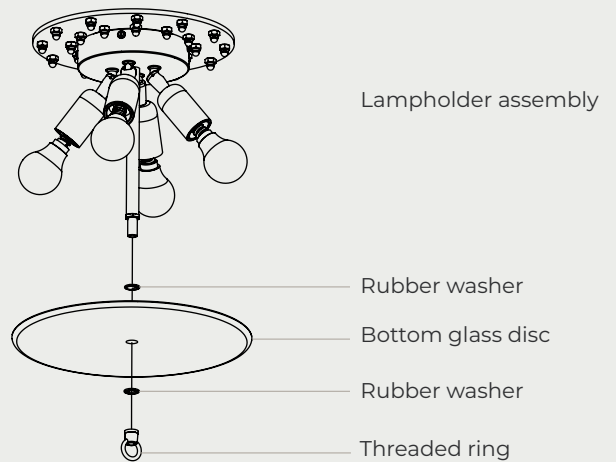

7. Using the diagram and the labeled glass, hang the vertical glass discs on to the cross-member's arms.

Start from the centre of the pendant (A4, B3, C3, D4) and evenly work your way outwards with the weight evenly distributed.

Note: a. Please see details 1-3 (below) for opening and closing the hooks to secure the glass disks.

b. Ensure that the coarse face of the glass is facing outwards and that they are all spaced evenly.

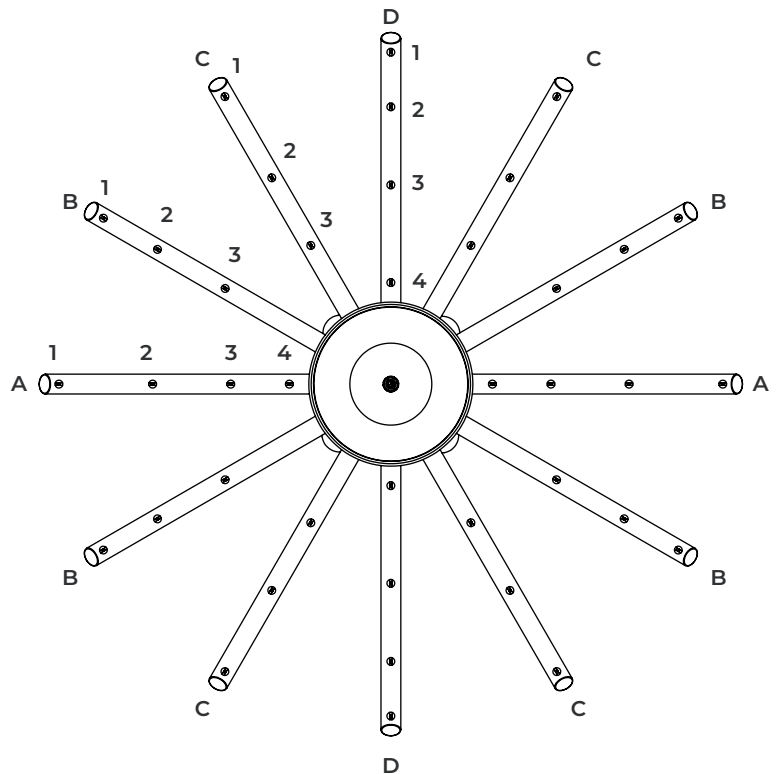
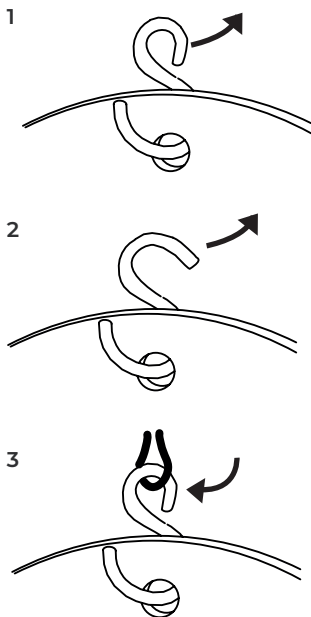

Using a pair of pliers, carefully open the glass mounting hooks (1) wide enough to fit the pin, attached on the frame (2). Fit the hooks to the pin and carefully close the hooks with the pliers (3) taking care not to damage the glass or the fitting.

8. Hang the remaining 250mm diam. glass disc from the threaded brass ring at the bottom of the pendant, as shown in the diagram.

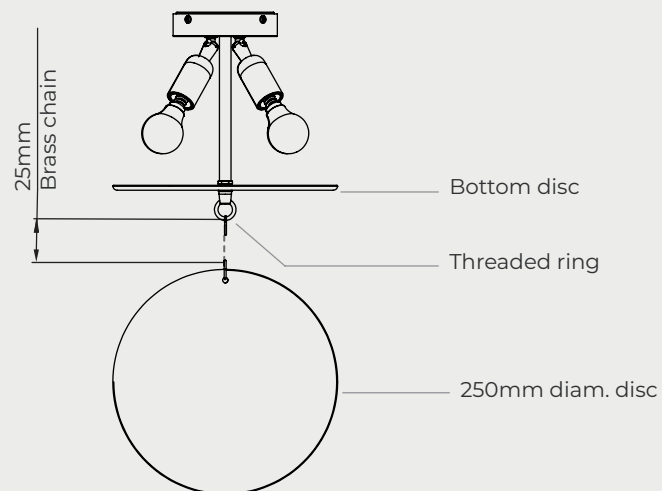

MAINTENANCE

Cleaning

Dust using a dry lint-free cloth weekly or as required

Repairs

Contact
CTO Lighting

Warranty

Please visit
[www.ctolighting.co.uk/
pages/f-a-q](http://www.ctolighting.co.uk/pages/f-a-q)
for CTO warranty policy

Certification

