

RING WALL

Installation Guide

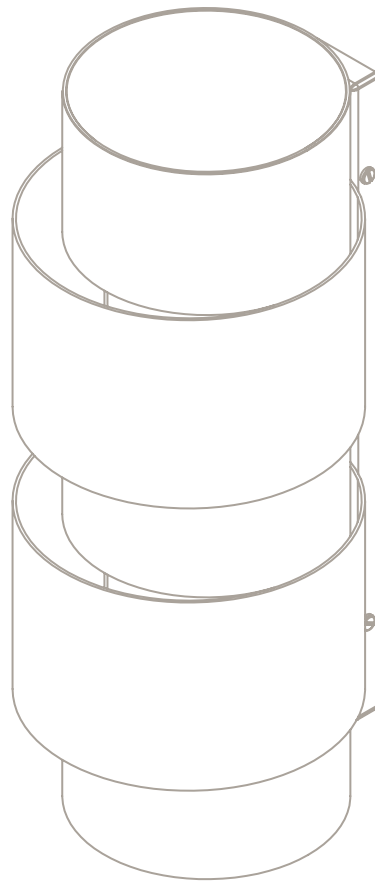

!

Please handle with care and wear gloves at all times during assembly and installation to avoid damaging components.

TECHNICAL

Bulb Holder
240v - 2 x G9
120v - 2 x G9
(bulbs not supplied)

Wattage
25w max halogen
(or 2.3w LED 2700k)

Weight
4kg (8.8lbs)

PARTS & COMPONENTS

A. Ring Wall light, Mounting plate and 4 x M4 screws

Additional parts for US installation only:

B. Covering Plate

C. US Adapter plate

A.

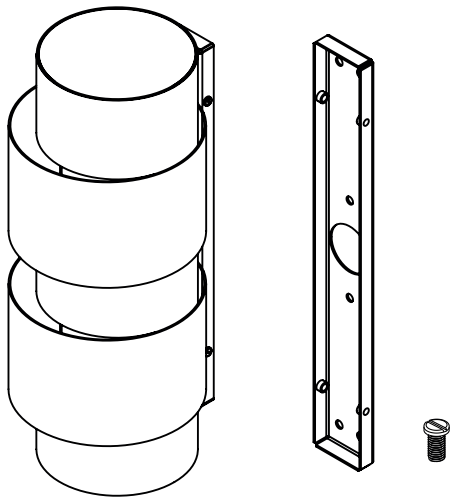

B.

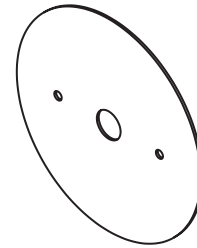

C.

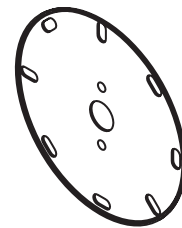



BEFORE INSTALLATION

- Check that you have all components before starting the installation.
 - Installation must be carried out by a qualified electrician.
 - A minimum of two people is required to install a pendant light.
- Check that the ceiling or wall fixings are suitable and strong enough to support the weight of the light fixture.
 - You will need the below specific tools for a successful installation.

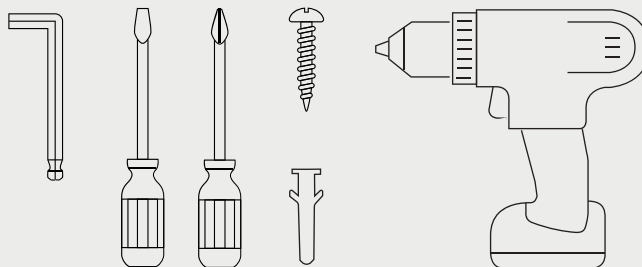

1. Remove the wall plate from the fitting by removing the four screws located on the sides of the back plate.

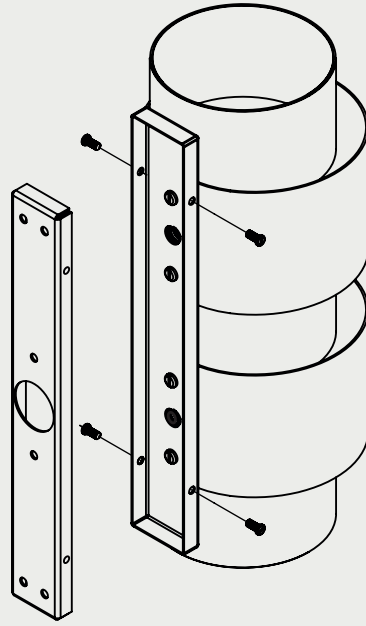

2. 240V

Securely fix the mounting plate to the wall in the correct position using suitable fixings for the surface you are mounting to (not supplied).



2. 110V

US

Securely fix the US adapter plate to junction box ensuring that the three central holes are vertically positioned (1).

Attach the mounting plate and covering plate to the Adapter plate using the 2 screws provided (2) to securely attach the wall plate to the junction box (3).

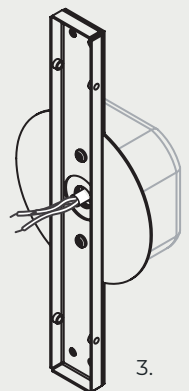
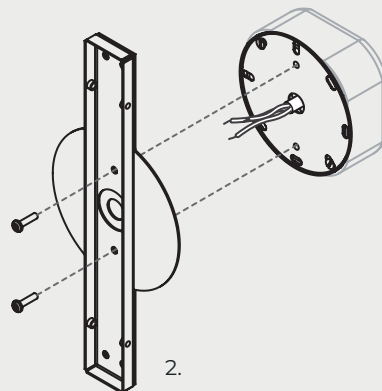
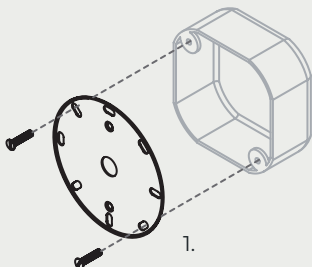

3. A. Raise the wall light and make the electrical connections inside the wall cover plate ensuring all wires are colour matched and the wall light is earthed correctly.
- B. Bring the wall cover plate up to the mounted plate and secure with the four screws.

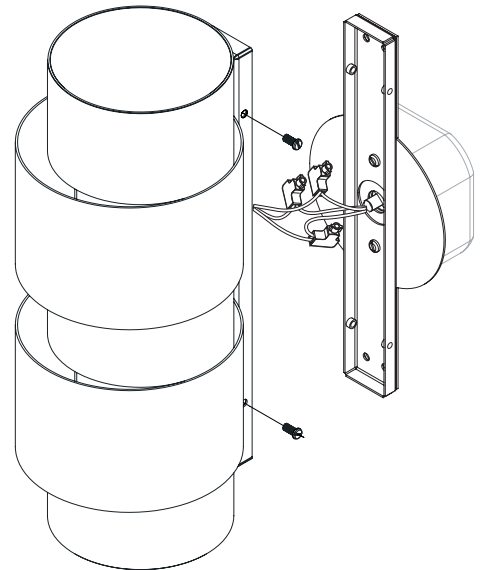
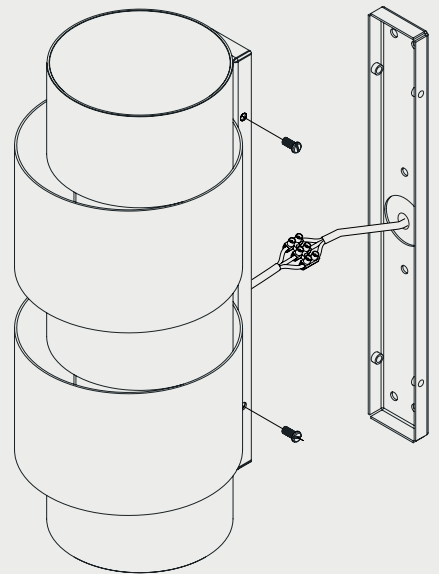

MAINTENANCE

Cleaning

Dust using a dry lint-free cloth weekly or as required

Repairs

Contact
CTO Lighting

Warranty

Please visit
[www.ctolighting.co.uk/
pages/f-a-q](http://www.ctolighting.co.uk/pages/f-a-q)
for CTO warranty policy

Certification



E492308