

SASHA PENDANT

Installation Guide

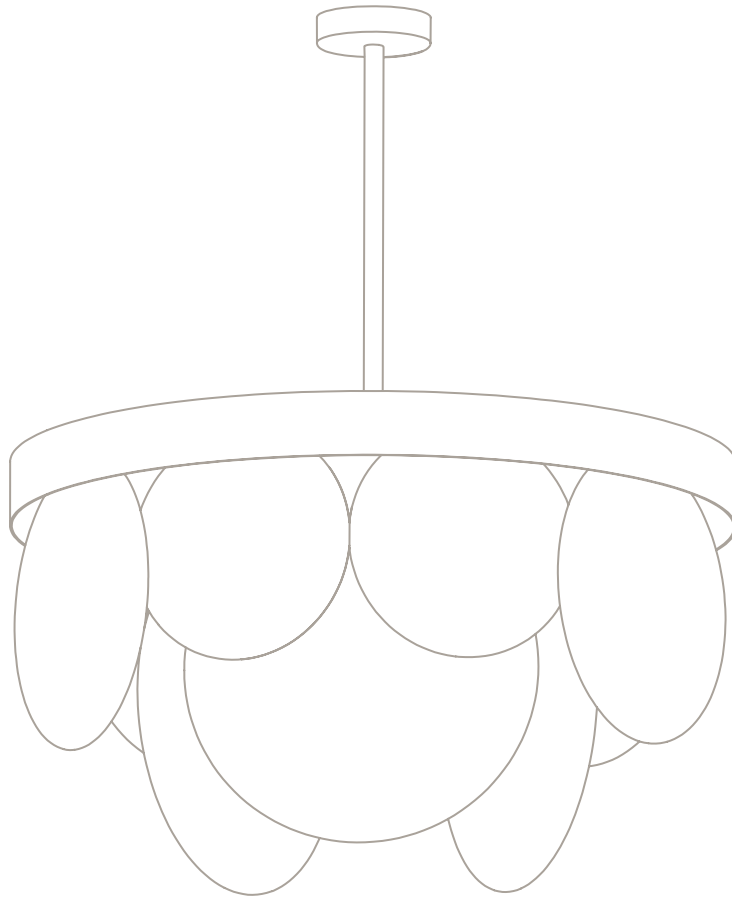

!

Please handle with care and wear gloves at all times during assembly and installation to avoid damaging components.

TECHNICAL

Bulb Holder
 240v - 3 x E14
 120v - 3 x E12
 (no bulbs supplied)

Wattage
 40w max halogen
 (or 6.5w LED 2700k)

Weight
 20kg (44.1lbs)

PARTS & COMPONENTS

- A. 1 x Sasha body
- B. 1 x Lamp holder assembly with 3 x bulb covers
- C. Glass discs – 6 x 200mm diam., 3 x 250mm diam., 3 x 300mm diam.
- D. 1 x Bottom glass disk
- E. 1 x Ceiling rose cover, drop rod and Mounting plate

A.

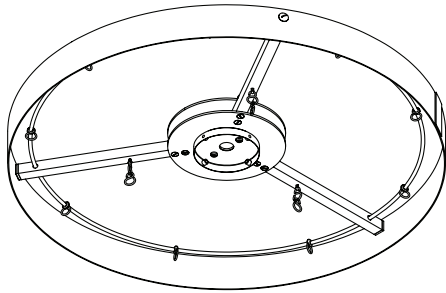

B.

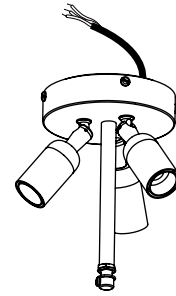

C.

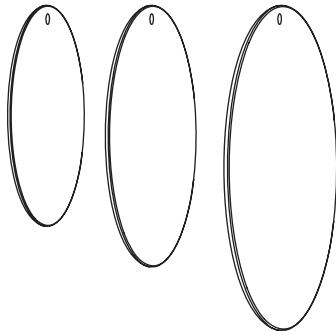

D.

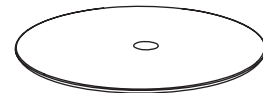

E.

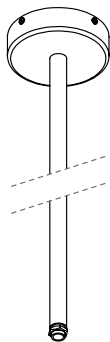

- All nuts and bolts required for assembling the light are included.



BEFORE INSTALLATION

- Check that you have all components before starting the installation.
 - Installation must be carried out by a qualified electrician.
 - A minimum of two people is required to install a pendant light.
- Check that the ceiling or wall fixings are suitable and strong enough to support the weight of the light fixture.
 - You will need the below specific tools for a successful installation.

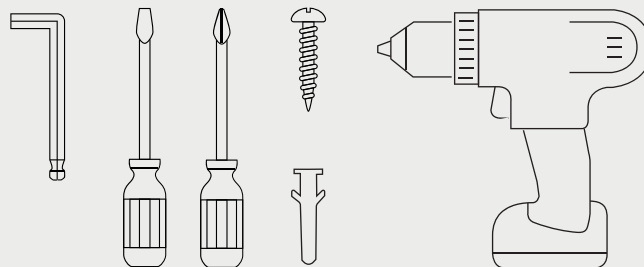

HEIGHT ADJUSTMENT INSTRUCTIONS

Before attaching the drop rod to the body of the light, calculate the required total drop from ceiling to bottom of pendant. If any height adjustment is required, follow the steps below:

1. Separate the brass tube and the internal threaded tube from the ceiling rose cover by unscrewing the bolt.

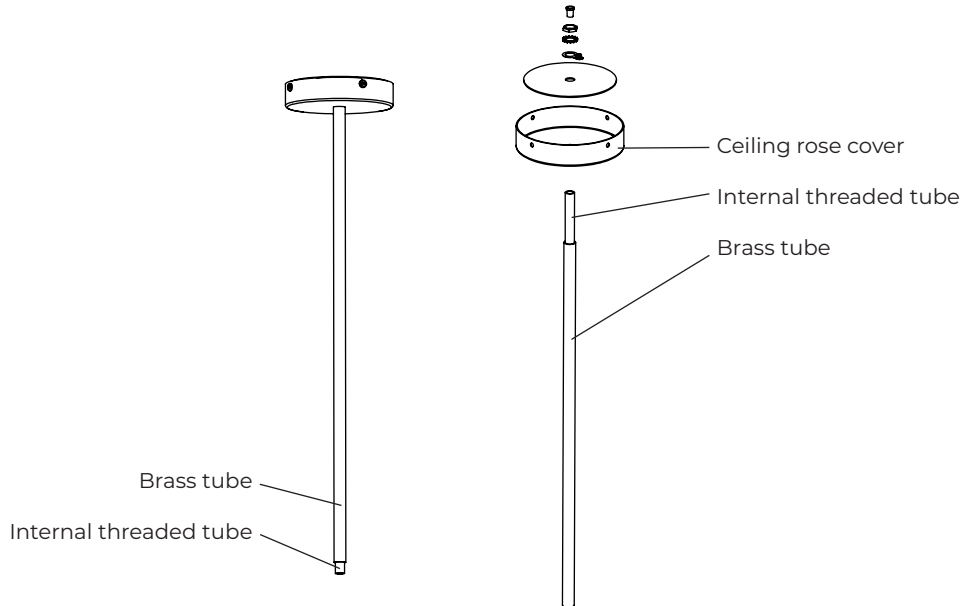

2. Measure the length the drop rod needs to be.
3. Cut the brass tube to this length using a hacksaw or similar tool.
4. Cut the same length from the internal threaded tube.

NOTE: Internal threaded tube must always be longer than the brass tube.

5. Once the brass tube and internal threaded tube are cut to correct lengths, slide the brass tube over the internal threaded tube and attach them back to the ceiling rose cover by using components provided.

6. Once satisfied with the fit, secure bolts and all-thread with Loc-tite or similar adhesive.

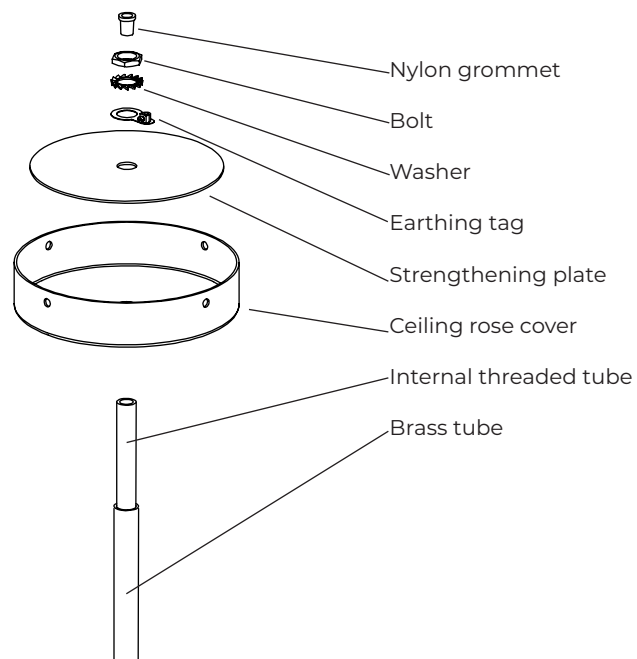

1. Remove the 6 x dome head nuts from the top of the main body part and remove the flat brass disk.

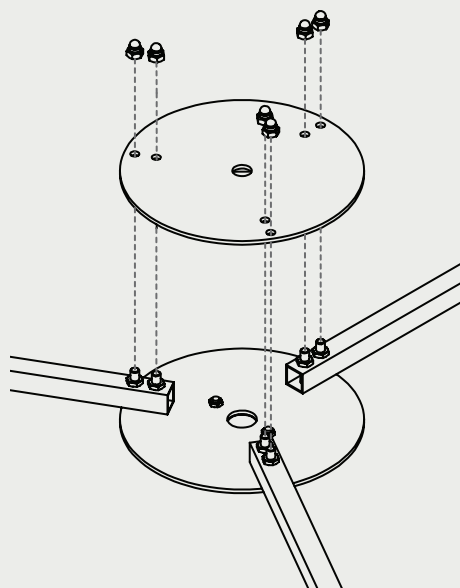

2. Remove the bolt from the bottom of the drop rod and place the brass disk onto the end.
Ensure that the nut is securely fastened.

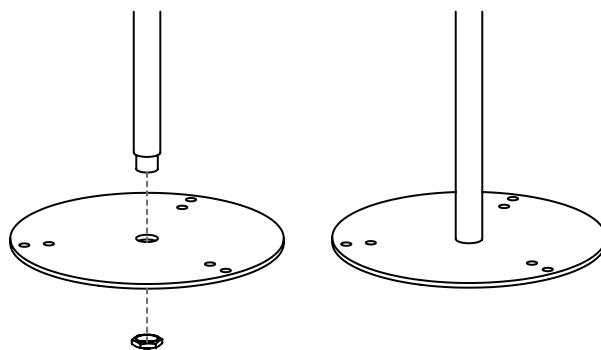

3. Thread the cable through the main body and raise the lamp holder assembly closing the lower box.
Use 4 x M4 machine screws (supplied) to secure the box.

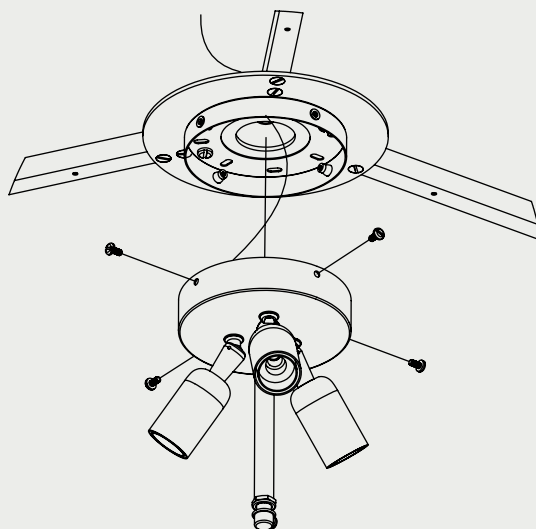

4. Thread the cable through the drop rod and re-attach the drop rod to the main body using the 6 x dome head nuts previously removed.

Ensure that the dome nuts are securely and tightly fastened.

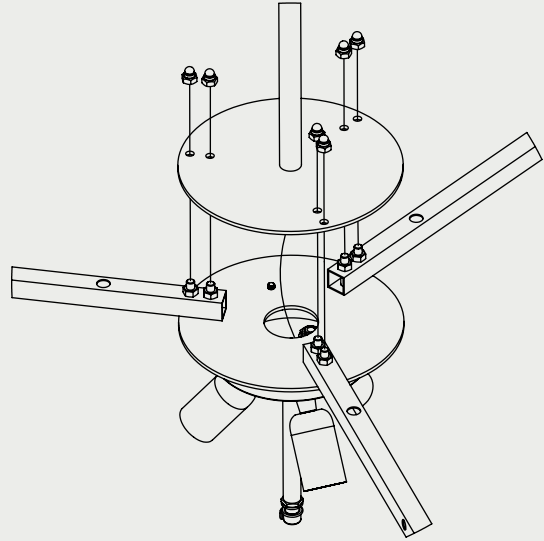

5. Fix the mounting plate to the ceiling. Ensure that suitable screws are being used for the surface that you are mounting to (not supplied).

Raise the pendant and make the electrical connections ensuring all wires are colour matched and the pendant is earthed correctly.

Bring the ceiling rose up to the mounted plate and secure using provided screws.

Note: Ensure that the weight of the pendant is fully supported during the electrical installation.

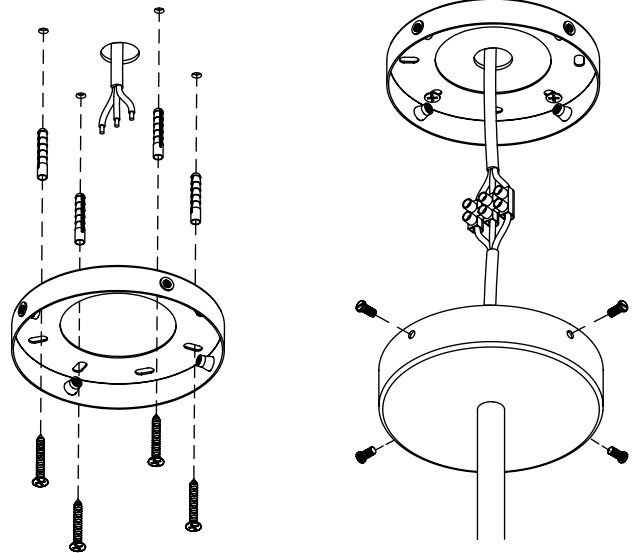

5. US

120v

Fix the mounting plate to the junction box using suitable screws (not supplied).

Raise the pendant and make the electrical connections inside the junction box ensuring all wires are colour matched and the pendant is earthed correctly.

Bring the ceiling rose up to the mounted plate and secure using provided screws.

Note: Ensure that the weight of the pendant is fully supported during the electrical installation.

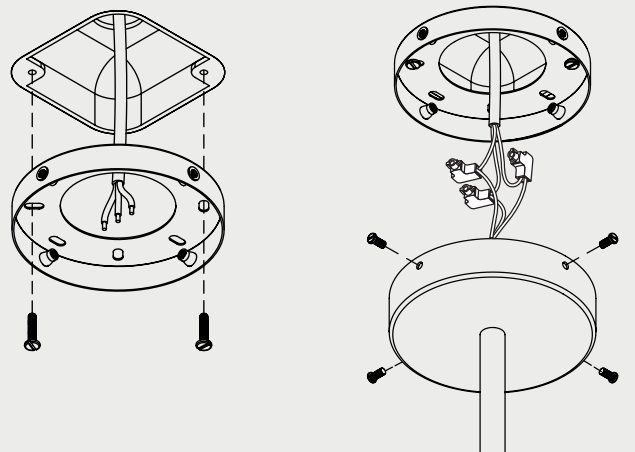

6. Remove and replace the finial from the bottom of the lamp holder assembly to fit the bottom glass disk, ensuring that the coarse face of the glass disk is facing down and that there is a rubber washer on each side.

Do not over tighten when replacing the finial as it may cause the glass disk to crack.

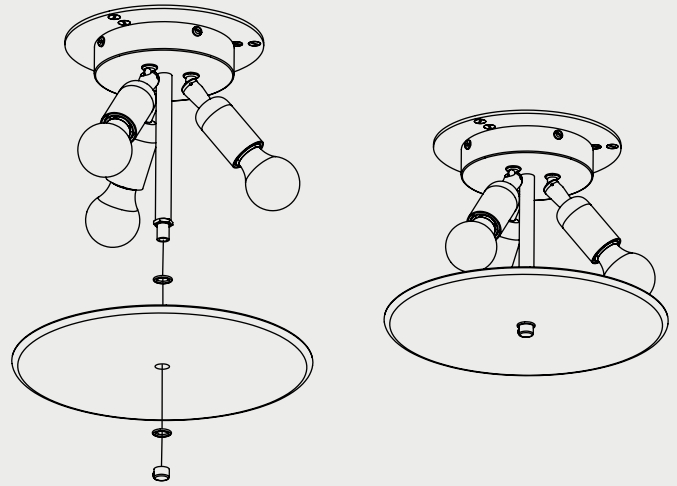

7. Mount the glass disks to the hooks located on the underside of the main body using the diagram.

Please see details 1-4 (below) for details on opening and closing the hooks to secure the glass disks.

Ensure that the coarse face of the glass is facing outwards and that they are all spaced evenly.

A 300mm diam.
B 250mm diam.
C 200mm diam.

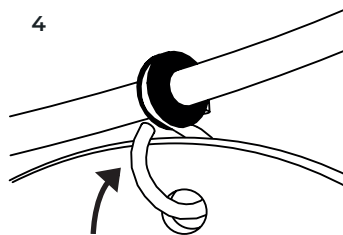
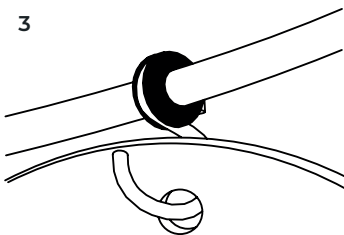
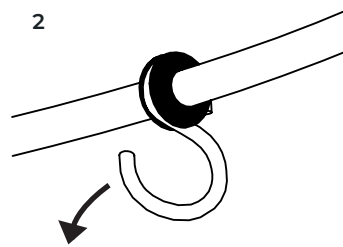
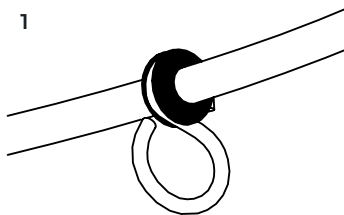
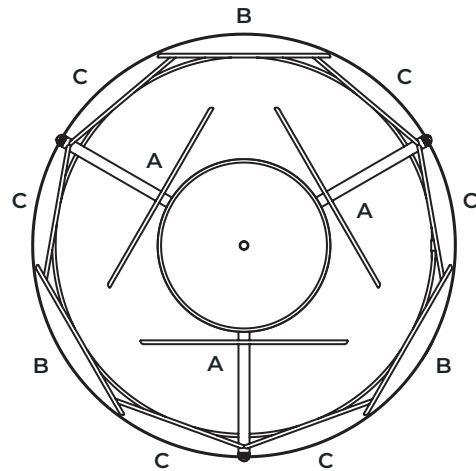

Using a pair of pliers, carefully open the glass mounting hooks (1) wide enough to fit the glass disks (2).

Fit the glass disks to the hooks (3) carefully close the hooks with the pliers (4) taking care not to damage the glass or the fitting.

MAINTENANCE

Cleaning

Dust using a dry lint-free cloth weekly or as required

Repairs

Contact
CTO Lighting

Warranty

Please visit
[www.ctolighting.co.uk/
pages/f-a-q](http://www.ctolighting.co.uk/pages/f-a-q)
for CTO warranty policy

Certification

 
E492308